

**NOTE:**

THE BOUNDARY INFORMATION SHOWN ON THIS PLAN REGARDING THE LOCATION OF THE PROPERTY BOUNDARIES HAS BEEN TAKEN FROM THE TITLE DEPOSITED PLAN. IT HAS BEEN PLOTTED AS REQUIRED UNDER DIVISION 1, SECTION 9(1) OF THE 'SURVEYING AND SPATIAL INFORMATION REGULATION 2017' AND IS ACCURATE TO ABOUT 20/100. IT HAS NOT BEEN DETERMINED BY AN ACCURATE BOUNDARY SURVEY.

A DETAIL & LEVEL SURVEY IS NOT A 'LAND SURVEY' AS DEFINED BY THE SURVEYING AND SPATIAL INFORMATION ACT, 2002. IF ANY CONSTRUCTION OR DESIGN WORK WHICH RELIES ON CRITICAL SETBACKS FROM THE STREET OR BOUNDARIES IS PLANNED, IT WOULD BE IMPERATIVE TO CARRY OUT FURTHER SURVEY WORK TO DETERMINE THE BOUNDARY DIMENSIONS.

PRIOR TO ANY CONSTRUCTION WORK, SURVEY MARKS SHOULD BE PLACED TO DEFINE THE PROPERTY BOUNDARIES.

SERVICES SHOWN ARE INDICATIVE ONLY. POSITIONS ARE BASED ON SURFACE INDICATOR(S) LOCATED DURING FIELD SURVEY. CONFIRMATION OF THE EXACT POSITION SHOULD BE MADE PRIOR TO ANY EXCAVATION WORK. OTHER SERVICES MAY EXIST WHICH ARE NOT SHOWN.

LEVELS ARE BASED ON AUSTRALIAN HEIGHT DATUM (AHD) USING SSM 61712 WITH RL 29.20 (AHD).

RIDGE & GUTTER HEIGHTS HAVE BEEN OBTAINED BY INDIRECT METHOD AND ARE ACCURATE TO ± 0.05m.

CONTOURS SHOWN DEPICT THE TOPOGRAPHY EXCEPT AT SPOT LEVELS SHOWN THEY DO NOT REPRESENT THE EXACT LEVEL AT ANY PARTICULAR POINT. THE SPOT LEVELS ARE TRUE FOR THEIR POSITION, AND ARE INTENDED TO BE USEFUL TO REPRESENT THE GENERAL TERRAIN. CARE SHOULD BE TAKEN IF EXTRAPOLATING.

- (A) EASEMENT FOR TRANSMISSION LINE VARIABLE WIDTH (500822)
- (B) PROPOSED EASEMENT FOR UNDERGROUND ELECTRICITY CABLE 1 WIDE (DP69296)
- (C) RIGHT OF CARRIAGEWAY VARIABLE WIDTH
- (D) EASEMENT FOR ELECTRICITY PURPOSES 5.0 WIDE AND VARIABLE.

ADDITIONAL TREES THAT FALL WITHIN THE DENOTED TREE QUADRANTS ARE REFERRED TO IN THE TREE QUADRANT REPORT No. 202159-5.

BOUNDARIES HAVE NOT BEEN LOCATED BY SURVEY. THE BOUNDARIES SHOWN ON THIS PLAN HAVE BEEN TAKEN FROM THE TITLE DEPOSITED PLAN AND ARE APPROXIMATE RELATIVE TO THE DETAIL SURVEY.

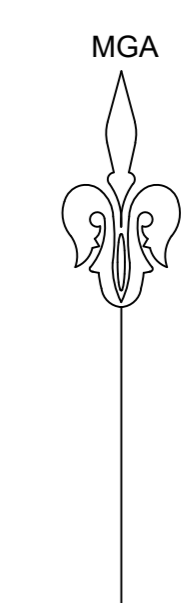

**STRATHFIELD COUNCIL RECEIVED**  
**S8.2 DA2021.52**  
**DATE 3 February 2022**

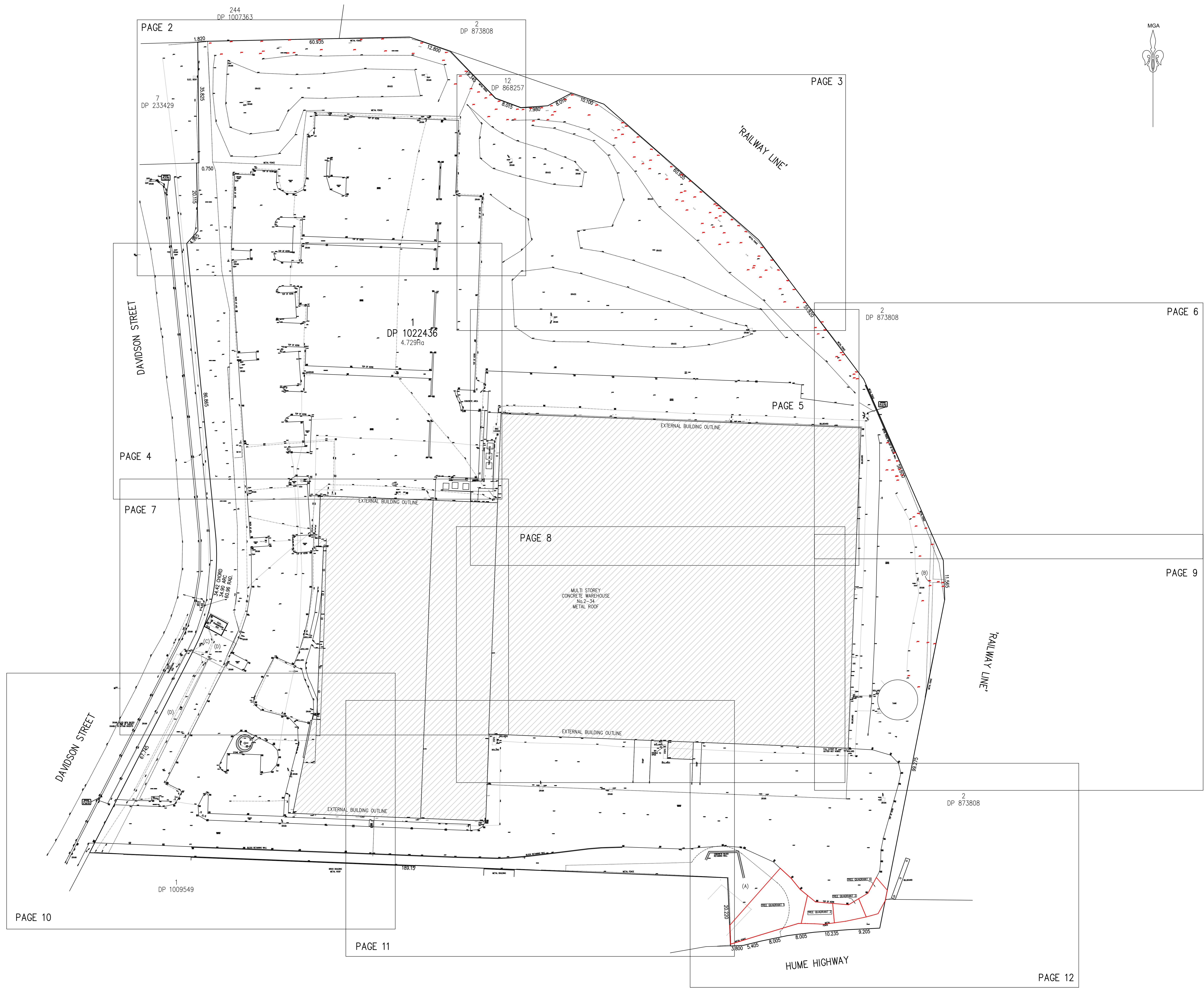

**LEGEND**

BENCH MARK	•
TELSTRA PIT	TEL
ELECTRIC LIGHT POLE	LP
POWER POLE	PP
SIGN POST	SP
SEWER INSPECTION PIT	SIP
SEWER VENT	SEWER
MANHOLE	MH
SEWER MANHOLE	SMH
STOP VALVE	SV
WATER HYDRANT	HYD
WATER METER	WM
GAS METER	GM
STATE SURVEY MARK	SSM

**TSS TOTAL SURVEYING SOLUTIONS**  
 LANE COVE | CAMDEN | MANLY VALE | CENTRAL COAST

**NOTE:**  
 INFORMATION CONTAINED IN THIS PLAN IS THE COPYRIGHT OF TOTAL SURVEYING SOLUTIONS. THE USE OR DUPLICATION WITHOUT THE WRITTEN CONSENT OF TOTAL SURVEYING SOLUTIONS CONSTITUTES AN INFRINGEMENT OF COPYRIGHT.

REVISION No.	REVISION DATE:	COMMENT:
2	25/11/2020	ADDITIONAL STORMWATER INVERT ADDED AND UPDATE DRAFTING
3	11/02/2021	EXTRA LEVELS AROUND BOUNDARY
4	04/05/2021	UPDATE SUFFIXES DENOTING ROOF RIDGES, GUTTERS AND AWNINGS
5	12/07/2021	ADD TREES ADJACENT TO THE SOUTHERN BOUNDARY

**LEGEND:**

EB - EDGE OF BITUMEN	TG - TOP OF GUTTER
EC - EDGE OF CONCRETE	RR - ROOF RIDGE
TB - TOP OF BANK	FL - FLOOR LEVEL
BB - BOTTOM OF BANK	INV - INVERT LEVEL
TW - TOP OF WINDOW	ELEC - ELECTRICAL PIT
AWN - TOP OF AWNING	Ø.4/S10/H16 - DIAMETER/SPREAD/HEIGHT

**PLAN SHOWING DETAIL & LEVELS OVER LOT 1 IN DP 1022436**

CLIENT: NEXT LEVEL UP CONSTRUCTION SERVICES PTY LTD	DATE: 20/11/2020	SCALE: 1:100@A0
PROJECT: CHULLORA	DRAWN: CC	CONT. INTERVAL: 0.25m
ADDRESS: 2-34 DAVIDSON ROAD, CHULLORA	CHK: MB	SHEET 1 OF 12

JOB No.: 202159	LGA: STRATHFIELD
PLAN No.: 202159-2	DATUM: AHD
DATE: 20/11/2020	SCALE: 1:100@A0
DRAWN: CC	CONT. INTERVAL: 0.25m
CHK: MB	SHEET 1 OF 12



**NOTE:**

THE BOUNDARY INFORMATION SHOWN ON THIS PLAN REGARDING THE LOCATION OF THE PROPERTY BOUNDARIES HAS BEEN TAKEN FROM THE TITLE DEPOSITED PLAN. IT HAS BEEN PLOTTED AS REQUIRED UNDER DIVISION 1, SECTION 9(1) OF THE 'SURVEYING AND SPATIAL INFORMATION REGULATION 2017' AND IS ACCURATE TO ABOUT 0.05m. IT HAS NOT BEEN DETERMINED BY AN ACCURATE BOUNDARY SURVEY.

A DETAIL & LEVEL SURVEY IS NOT A 'LAND SURVEY' AS DEFINED BY THE SURVEYING AND SPATIAL INFORMATION ACT, 2002. IF ANY CONSTRUCTION OR DESIGN WORK WHICH RELIES ON CRITICAL SETBACKS FROM THE STREET OR BOUNDARIES IS PLANNED, IT WOULD BE IMPERATIVE TO CARRY OUT FURTHER SURVEY WORK TO DETERMINE THE BOUNDARY DIMENSIONS.

PRIOR TO ANY CONSTRUCTION WORK, SURVEY MARKS SHOULD BE PLACED TO DEFINE THE PROPERTY BOUNDARIES.

SERVICES SHOWN ARE INDICATIVE ONLY. POSITIONS ARE BASED ON SURFACE INDICATOR(S) LOCATED DURING FIELD SURVEY. CONFIRMATION OF THE EXACT POSITION SHOULD BE MADE PRIOR TO ANY EXCAVATION WORK. OTHER SERVICES MAY EXIST WHICH ARE NOT SHOWN.

LEVELS ARE BASED ON AUSTRALIAN HEIGHT DATUM (AHD) USING GSN 67112 WITH RL 29.20 (AHD).

RIDGE & GUTTER HEIGHTS HAVE BEEN OBTAINED BY INDIRECT METHOD AND ARE ACCURATE TO ± 0.05m.

CONTOURS SHOWN DEPICT THE TOPOGRAPHY EXCEPT AT SPOT LEVELS SHOWN THEY DO NOT REPRESENT THE EXACT LEVEL AT ANY PARTICULAR POINT. THE SPOT LEVELS ARE TRUE FOR THEIR POSITION, AND ARE INTENDED TO BE USEFUL TO REPRESENT THE GENERAL TERRAIN. CARE SHOULD BE TAKEN IF EXTRAPOLATING.

- (A) EASEMENT FOR TRANSMISSION LINE VARIABLE WIDTH (5008320)
- (B) PROPOSED EASEMENT FOR UNDERGROUND ELECTRICITY CABLE 1 WIDE (DPS02290)
- (C) RIGHT OF CARRIAGEWAY VARIABLE WIDTH
- (D) EASEMENT FOR ELECTRICITY PURPOSES 5.0 WIDE AND VARIABLE.

ADDITIONAL TREES THAT FALL WITHIN THE DENOTED TREE QUADRANTS ARE REFERRED TO IN THE TREE QUADRANT REPORT No. 202159-5.

BOUNDARIES HAVE NOT BEEN LOCATED BY SURVEY. THE BOUNDARIES SHOWN ON THIS PLAN HAVE BEEN TAKEN FROM THE TITLE DEPOSITED PLAN AND ARE APPROXIMATE RELATIVE TO THE DETAIL SURVEY.



**STRATHFIELD COUNCIL RECEIVED**  
 S8.2 DA2021.52  
 DP 233429  
 DATE 3 February 2022

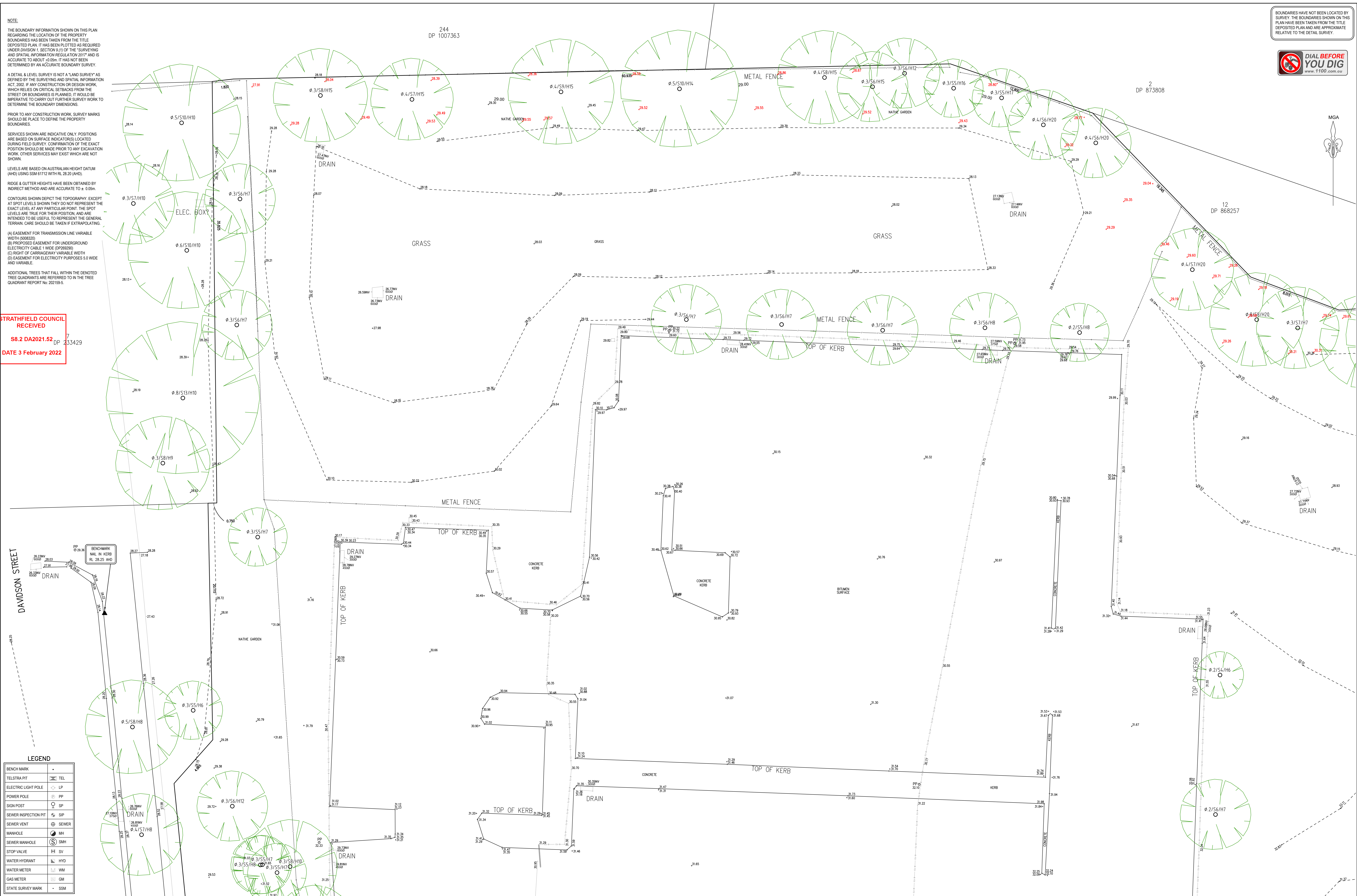

**LEGEND**

BENCH MARK	•
TELSTRA PIT	TEL
ELECTRIC LIGHT POLE	LP
POWER POLE	PP
SIGN POST	SP
SEWER INSPECTION PIT	SIP
SEWER VENT	SEWER
MANHOLE	MH
SEWER MANHOLE	SMH
STOP VALVE	SV
WATER HYDRANT	HYD
WATER METER	WM
GAS METER	GM
STATE SURVEY MARK	SSM

**NOTE:**  
 INFORMATION CONTAINED IN THIS PLAN IS THE COPYRIGHT OF TOTAL SURVEYING SOLUTIONS. THE USE OR DUPLICATION WITHOUT THE WRITTEN CONSENT OF TOTAL SURVEYING SOLUTIONS CONSTITUTES AN INFRINGEMENT OF COPYRIGHT.

REVISION No.	REVISION DATE:	COMMENT:
2	25/11/2020	ADDITIONAL STORMWATER INVERT ADDED AND UPDATE DRAFTING
3	11/02/2021	EXTRA LEVELS AROUND BOUNDARY
4	04/05/2021	UPDATE SUFFIXES DENOTING ROOF RIDGES, GUTTERS AND AWNINGS
5	12/07/2021	ADD TREES ADJACENT TO THE SOUTHERN BOUNDARY

**LEGEND:**

EB - EDGE OF BITUMEN
EC - EDGE OF CONCRETE
TB - TOP OF BANK
BB - BOTTOM OF BANK
TW - TOP OF WINDOW
AWN - TOP OF AWNING
TG - TOP OF GUTTER
RR - ROOF RIDGE
FL - FLOOR LEVEL
INV - INVERT LEVEL
ELEC - ELECTRICAL PIT
Ø.4/5/10/H16 - DIAMETER/SPREAD/HEIGHT

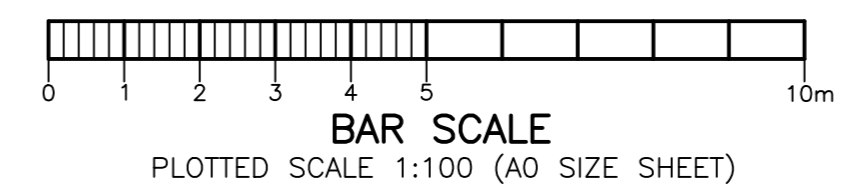

**PLAN SHOWING DETAIL & LEVELS**  
 OVER LOT 1 IN DP 1022436

CLIENT: NEXT LEVEL UP CONSTRUCTION SERVICES PTY LTD	PROJECT: CHULLORA
ADDRESS: 2-34 DAVIDSON ROAD, CHULLORA	

JOB No.: 202159	LGA: STRATHFIELD
PLAN No.: 202159-2	DATUM: AHD
DATE: 20/11/2020	SCALE: 1:100@A0
DRAWN: CC	CONT. INTERVAL: 0.25m
CHK: MB	SHEET 2 OF 12



NOTE:

THE BOUNDARY INFORMATION SHOWN ON THIS PLAN REGARDING THE LOCATION OF THE PROPERTY BOUNDARIES HAS BEEN TAKEN FROM THE TITLE DEPOSITED PLAN. IT HAS BEEN PLOTTED AS REQUIRED UNDER DIVISION 1, SECTION 9(1) OF THE 'SURVEYING AND SPATIAL INFORMATION REGULATION 2017' AND IS ACCURATE TO ABOUT ±0.05m. IT HAS NOT BEEN DETERMINED BY AN ACCURATE BOUNDARY SURVEY.

A DETAIL & LEVEL SURVEY IS NOT A 'LAND SURVEY' AS DEFINED BY THE SURVEYING AND SPATIAL INFORMATION ACT, 2002. IF ANY CONSTRUCTION OR DESIGN WORK WHICH RELIES ON CRITICAL SETBACKS FROM THE STREET OR BOUNDARIES IS PLANNED, IT WOULD BE IMPERATIVE TO CARRY OUT FURTHER SURVEY WORK TO DETERMINE THE BOUNDARY DIMENSIONS.

PRIOR TO ANY CONSTRUCTION WORK, SURVEY MARKS SHOULD BE PLACED TO DEFINE THE PROPERTY BOUNDARIES.

SERVICES SHOWN ARE INDICATIVE ONLY. POSITIONS ARE BASED ON SURFACE INDICATORS(S) LOCATED DURING FIELD SURVEY. CONFIRMATION OF THE EXACT POSITION SHOULD BE MADE PRIOR TO ANY EXCAVATION WORK. OTHER SERVICES MAY EXIST WHICH ARE NOT SHOWN.

LEVELS ARE BASED ON AUSTRALIAN HEIGHT DATUM (AHD) USING SSM 61712 WITH RL 29.20 (AHD).

RIDGE & GUTTER HEIGHTS HAVE BEEN OBTAINED BY INDIRECT METHOD AND ARE ACCURATE TO ± 0.05m.

CONTOURS SHOWN DEPICT THE TOPOGRAPHY EXCEPT AT SPOT LEVELS SHOWN THEY DO NOT REPRESENT THE EXACT LEVEL AT ANY PARTICULAR POINT. THE SPOT LEVELS ARE TRUE FOR THEIR POSITION, AND ARE INTENDED TO BE USEFUL TO REPRESENT THE GENERAL TERRAIN. CARE SHOULD BE TAKEN IF EXTRAPOLATING.

(A) EASEMENT FOR TRANSMISSION LINE VARIABLE WIDTH (5008320)  
(B) PROPOSED EASEMENT FOR UNDERGROUND ELECTRICITY CABLE 1 WIDE (DP20220)  
(C) RIGHT OF CARRIAGEWAY VARIABLE WIDTH  
(D) EASEMENT FOR ELECTRICITY PURPOSES 5.0 WIDE AND VARIABLE.

ADDITIONAL TREES THAT FALL WITHIN THE DENOTED TREE QUADRANTS ARE REFERRED TO IN THE TREE QUADRANT REPORT No. 202159-5.

BOUNDARIES HAVE NOT BEEN LOCATED BY SURVEY. THE BOUNDARIES SHOWN ON THIS PLAN HAVE BEEN TAKEN FROM THE TITLE DEPOSITED PLAN AND ARE APPROXIMATE RELATIVE TO THE DETAIL SURVEY.

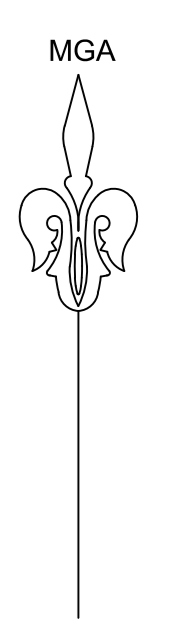

STRATHFIELD COUNCIL RECEIVED  
S8.2 DA2021.52  
DATE 3 February 2022

**LEGEND**

BENCH MARK	•
TELSTRA PIT	TEL
ELECTRIC LIGHT POLE	LP
POWER POLE	PP
SIGN POST	SP
SEWER INSPECTION PIT	SIP
SEWER VENT	SEWER
MANHOLE	MH
SEWER MANHOLE	SMH
STOP VALVE	SV
WATER HYDRANT	HYD
WATER METER	WM
GAS METER	GM
STATE SURVEY MARK	SSM



NOTE:  
INFORMATION CONTAINED IN THIS PLAN IS THE COPYRIGHT OF TOTAL SURVEYING SOLUTIONS. THE USE OR DUPLICATION WITHOUT THE WRITTEN CONSENT OF TOTAL SURVEYING SOLUTIONS CONSTITUTES AN INFRINGEMENT OF COPYRIGHT.

REVISION No.	REVISION DATE:	COMMENT:
2	25/11/2020	ADDITIONAL STORMWATER INVERT ADDED AND UPDATE DRAFTING
3	11/02/2021	EXTRA LEVELS AROUND BOUNDARY
4	04/05/2021	UPDATE SUFFIXES DENOTING ROOF RIDGES, GUTTERS AND AWNINGS
5	12/07/2021	ADD TREES ADJACENT TO THE SOUTHERN BOUNDARY

**LEGEND:**

EB - EDGE OF BITUMEN	TG - TOP OF GUTTER
EC - EDGE OF CONCRETE	RR - ROOF RIDGE
TB - TOP OF BANK	FL - FLOOR LEVEL
BB - BOTTOM OF BANK	INV - INVERT LEVEL
TW - TOP OF WINDOW	ELEC - ELECTRICAL PIT
AWN - TOP OF AWNING	Ø.4/S10/H16 - DIAMETER/SPREAD/HEIGHT

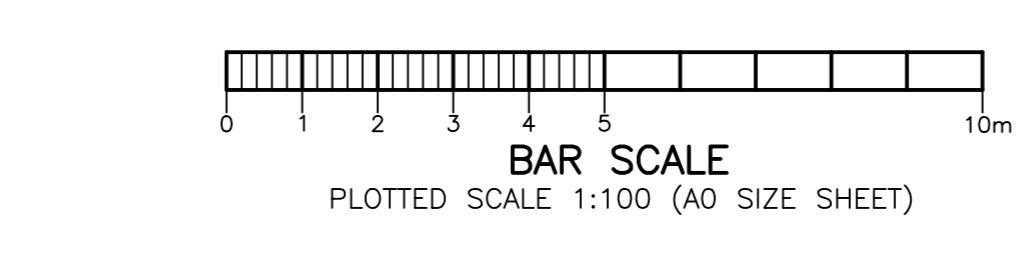

PLAN SHOWING DETAIL & LEVELS OVER LOT 1 IN DP 1022436		JOB No.: 202159	LGA: STRATHFIELD
CLIENT: NEXT LEVEL UP CONSTRUCTION SERVICES PTY LTD	DATE: 20/11/2020	PLAN No.: 202159-2	DATUM: AHD
PROJECT: CHULLORA	ADDRESS: 2-34 DAVIDSON ROAD, CHULLORA	SCALE: 1:100@A0	CONT. INTERVAL: 0.25m
DRAWN: CC	CHK: MB	SHEET 3 OF 12	

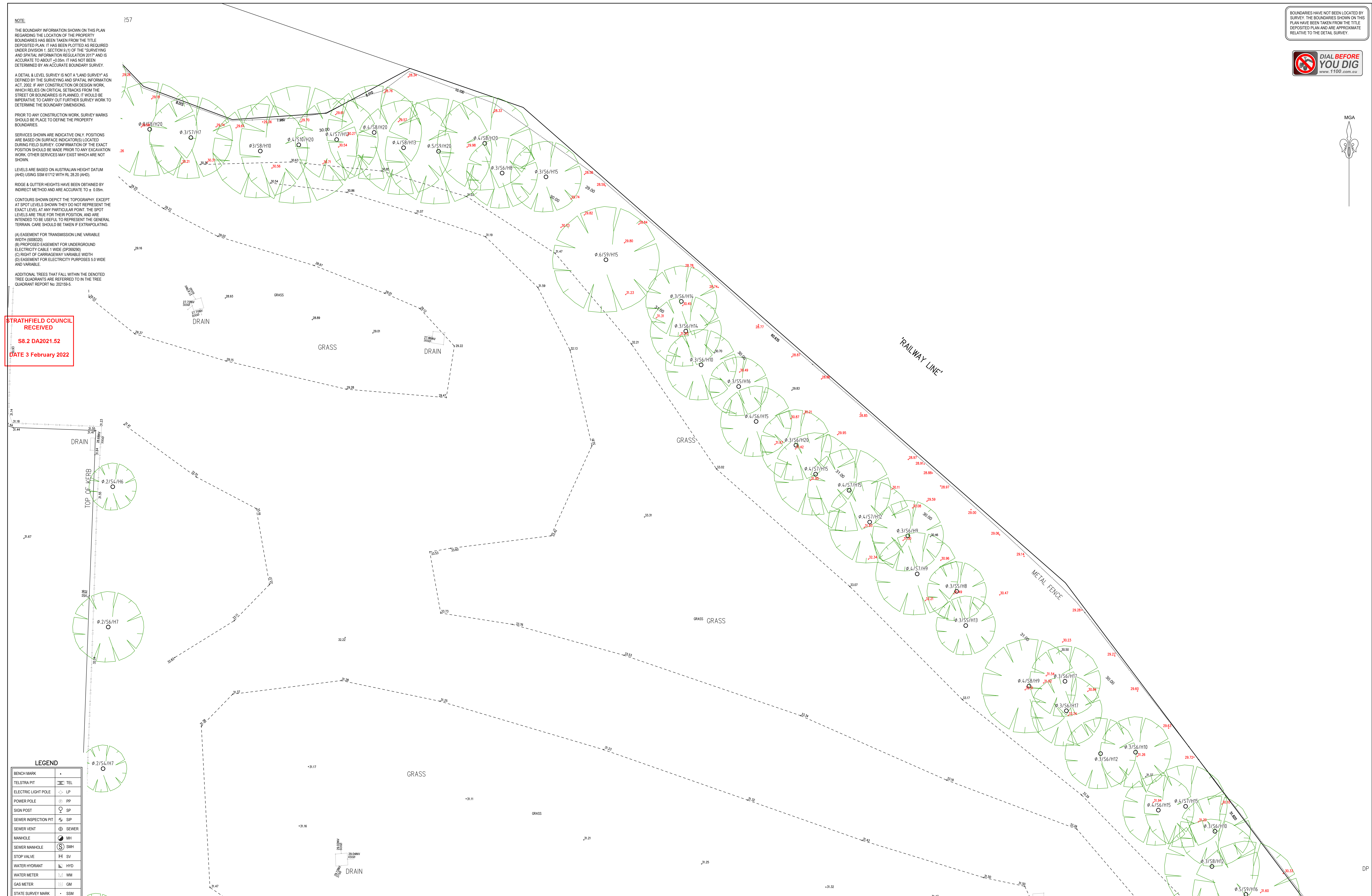



**NOTE:**  
 THE BOUNDARY INFORMATION SHOWN ON THIS PLAN REGARDING THE LOCATION OF THE PROPERTY BOUNDARIES HAS BEEN TAKEN FROM THE TITLE DEPOSITED PLAN. IT HAS BEEN PLOTTED AS REQUIRED UNDER DIVISION 1, SECTION 9(1) OF THE "SURVEYING AND SPATIAL INFORMATION REGULATION 2017" AND IS ACCURATE TO ABOUT 0.05m. IT HAS NOT BEEN DETERMINED BY AN ACCURATE BOUNDARY SURVEY.

A DETAIL & LEVEL SURVEY IS NOT A "LAND SURVEY" AS DEFINED BY THE SURVEYING AND SPATIAL INFORMATION ACT, 2002. IF ANY CONSTRUCTION OR DESIGN WORK WHICH RELIES ON CRITICAL SETBACKS FROM THE STREET OR BOUNDARIES IS PLANNED, IT WOULD BE IMPERATIVE TO CARRY OUT FURTHER SURVEY WORK TO DETERMINE THE BOUNDARY DIMENSIONS.

PRIOR TO ANY CONSTRUCTION WORK, SURVEY MARKS SHOULD BE PLACED TO DEFINE THE PROPERTY BOUNDARIES.

SERVICES SHOWN ARE INDICATIVE ONLY. POSITIONS ARE BASED ON SURFACE INDICATOR(S) LOCATED DURING FIELD SURVEY. CONFIRMATION OF THE EXACT POSITION SHOULD BE MADE PRIOR TO ANY EXCAVATION WORK. OTHER SERVICES MAY EXIST WHICH ARE NOT SHOWN.

LEVELS ARE BASED ON AUSTRALIAN HEIGHT DATUM (AHD) USING SSM 67112 WITH RL 29.20 (AHD).

RIDGE & GUTTER HEIGHTS HAVE BEEN OBTAINED BY INDIRECT METHOD AND ARE ACCURATE TO ± 0.05m.

CONTOURS SHOWN DEPICT THE TOPOGRAPHY EXCEPT AT SPOT LEVELS SHOWN THEY DO NOT REPRESENT THE EXACT LEVEL AT ANY PARTICULAR POINT. THE SPOT LEVELS ARE TRUE FOR THEIR POSITION, AND ARE INTENDED TO BE USEFUL TO REPRESENT THE GENERAL TERRAIN. CARE SHOULD BE TAKEN IF EXTRAPOLATING.

(A) EASEMENT FOR TRANSMISSION LINE VARIABLE WIDTH (5008320)  
 (B) PROPOSED EASEMENT FOR UNDERGROUND ELECTRICITY CABLE 1 WIDE (0500290)  
 (C) RIGHT OF CARRIAGEWAY VARIABLE WIDTH  
 (D) EASEMENT FOR ELECTRICITY PURPOSES 5.0 WIDE AND VARIABLE.

ADDITIONAL TREES THAT FALL WITHIN THE DENOTED TREE QUADRANTS ARE REFERRED TO IN THE TREE QUADRANT REPORT No. 202159-5.

**STRATHFIELD COUNCIL RECEIVED**  
**S8.2 DA2021.52**  
**DATE 3 February 2022**

BOUNDARIES HAVE NOT BEEN LOCATED BY SURVEY. THE BOUNDARIES SHOWN ON THIS PLAN HAVE BEEN TAKEN FROM THE TITLE DEPOSITED PLAN AND ARE APPROXIMATE RELATIVE TO THE DETAIL SURVEY.

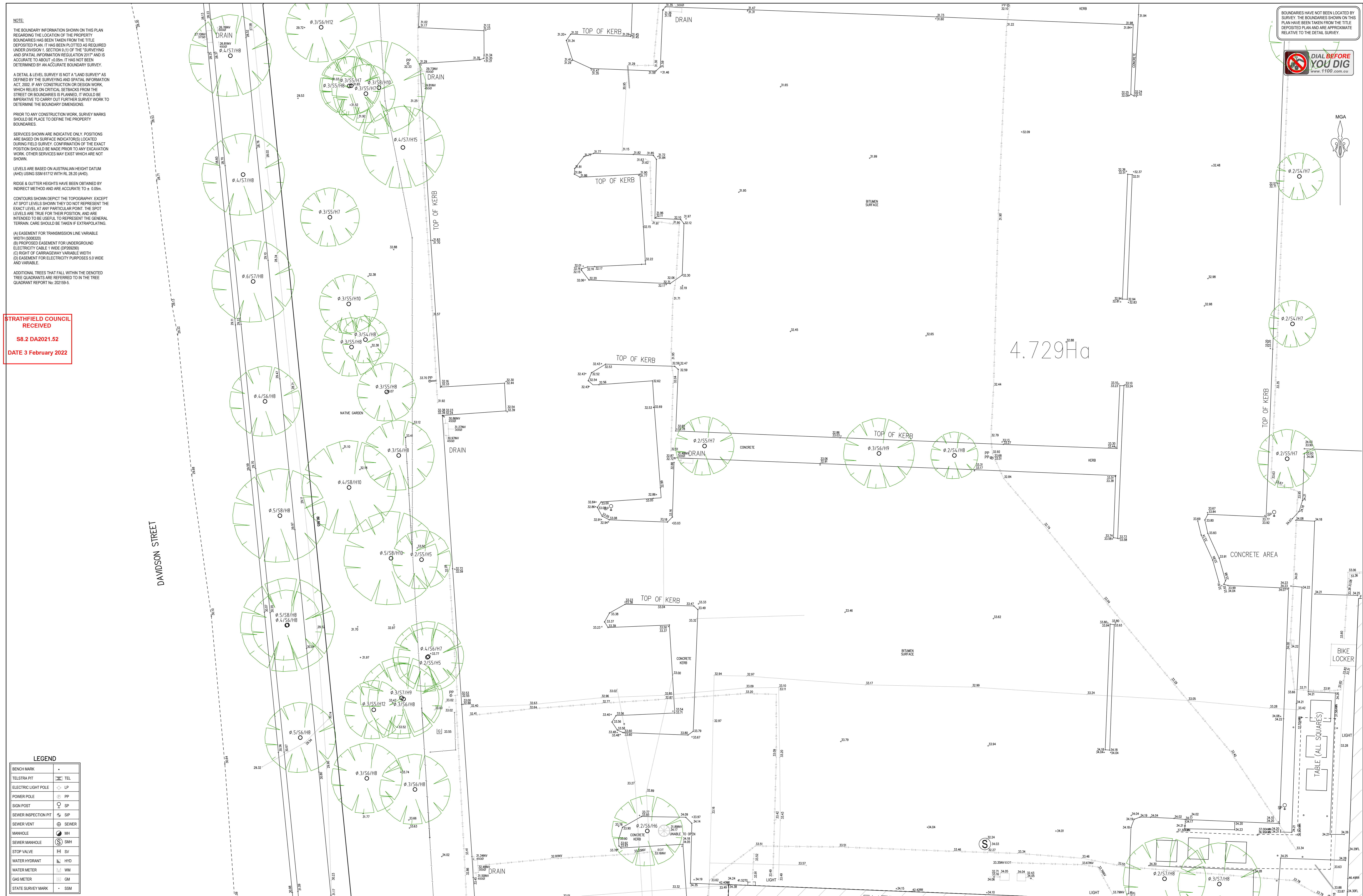

**LEGEND**

BENCH MARK	•
TELSTRA PIT	TEL
ELECTRIC LIGHT POLE	LP
POWER POLE	PP
SIGN POST	SP
SEWER INSPECTION PIT	SIP
SEWER VENT	SEWER
MANHOLE	MH
SEWER MANHOLE	SMH
STOP VALVE	SV
WATER HYDRANT	HYD
WATER METER	WM
GAS METER	GM
STATE SURVEY MARK	SSM

**NOTE:**  
 INFORMATION CONTAINED IN THIS PLAN IS THE COPYRIGHT OF TOTAL SURVEYING SOLUTIONS. THE USE OR DUPLICATION WITHOUT THE WRITTEN CONSENT OF TOTAL SURVEYING SOLUTIONS CONSTITUTES AN INFRINGEMENT OF COPYRIGHT.

REVISION No.	REVISION DATE:	COMMENT:
2	25/11/2020	ADDITIONAL STORMWATER INVERT ADDED AND UPDATE DRAFTING
3	11/02/2021	EXTRA LEVELS AROUND BOUNDARY
4	04/05/2021	UPDATE SUFFIXES DENOTING ROOF RIDGES, GUTTERS AND AWNINGS
5	12/07/2021	ADD TREES ADJACENT TO THE SOUTHERN BOUNDARY

**LEGEND:**

EB - EDGE OF BITUMEN
EC - EDGE OF CONCRETE
TB - TOP OF BANK
BB - BOTTOM OF BANK
TW - TOP OF WINDOW
AWN - TOP OF AWNING
TG - TOP OF GUTTER
RR - ROOF RIDGE
FL - FLOOR LEVEL
INV - INVERT LEVEL
ELEC - ELECTRICAL PIT
Ø.4/S10/H16 - DIAMETER/SPREAD/HEIGHT

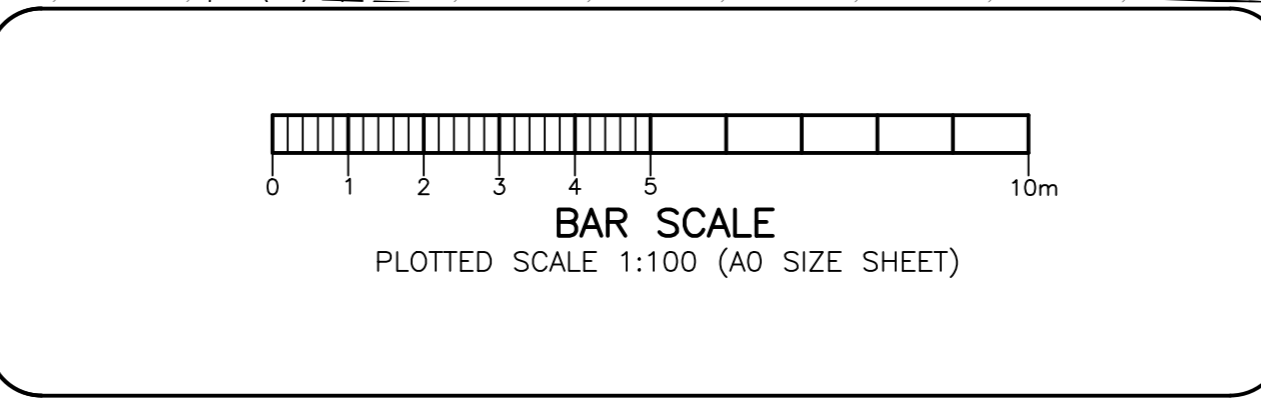

**PLAN SHOWING DETAIL & LEVELS**  
**OVER LOT 1 IN DP 1022436**  
 CLIENT: NEXT LEVEL UP CONSTRUCTION SERVICES PTY LTD  
 PROJECT: CHULLORA  
 ADDRESS: 2-34 DAVIDSON ROAD, CHULLORA

JOB No: 202159	LGA: STRATHFIELD
PLAN No: 202159-2	DATUM: AHD
DATE: 20/11/2020	SCALE: 1:100@A0
DRAWN: CC	CONT. INTERVAL: 0.25m
CHK: MB	SHEET 4 OF 12



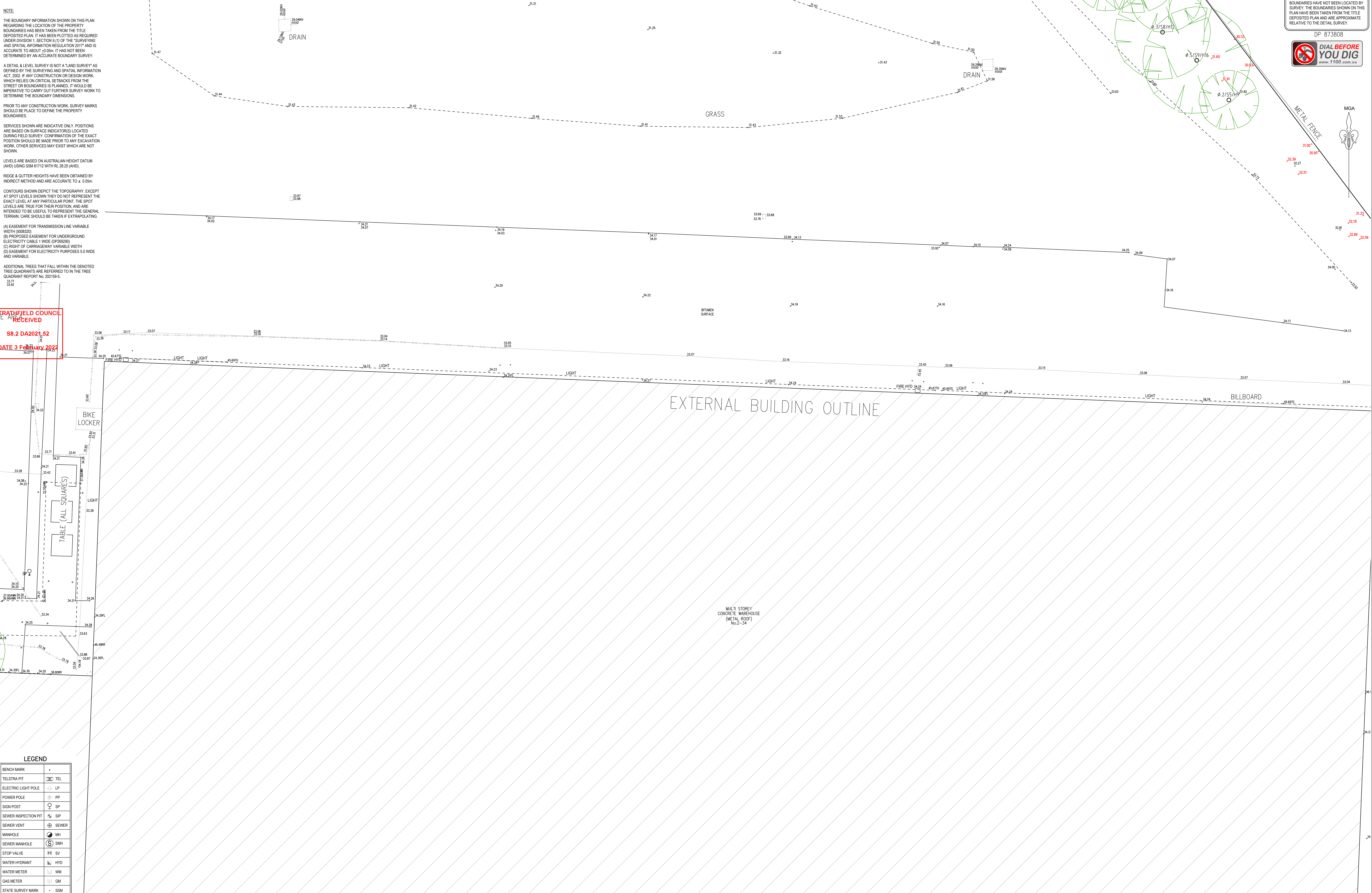

STRATHFIELD COUNCIL  
RECEIVED  
S8.2 DA2021-52  
DATE 3 February 2022

**LEGEND**

BENCH MARK	•
TELSTRA PIT	TEL
ELECTRIC LIGHT POLE	LP
POWER POLE	PP
SIGN POST	SP
SEWER INSPECTION PIT	SIP
SEWER VENT	SEWER
MANHOLE	MH
SEWER MANHOLE	SMH
STOP VALVE	SV
WATER HYDRANT	HYD
WATER METER	WM
GAS METER	GM
STATE SURVEY MARK	SSM

**NOTE:**  
INFORMATION CONTAINED IN THIS PLAN IS THE COPYRIGHT OF TOTAL SURVEYING SOLUTIONS. THE USE OR DUPLICATION WITHOUT THE WRITTEN CONSENT OF TOTAL SURVEYING SOLUTIONS CONSTITUTES AN INFRINGEMENT OF COPYRIGHT.

REVISION No.	REVISION DATE:	COMMENT:
2	25/11/2020	ADDITIONAL STORMWATER INVERT ADDED AND UPDATE DRAFTING
3	11/02/2021	EXTRA LEVELS AROUND BOUNDARY
4	04/05/2021	UPDATE SUFFIXES DENOTING ROOF RIDGES, GUTTERS AND AWNINGS
5	12/07/2021	ADD TREES ADJACENT TO THE SOUTHERN BOUNDARY

**LEGEND:**

EB - EDGE OF BITUMEN	TG - TOP OF GUTTER
EC - EDGE OF CONCRETE	RR - ROOF RIDGE
TB - TOP OF BANK	FL - FLOOR LEVEL
BB - BOTTOM OF BANK	INV - INVERT LEVEL
TW - TOP OF WINDOW	ELEC - ELECTRICAL PIT
AWN - TOP OF AWNING	Ø.4/S10/H16 - DIAMETER/SPREAD/HEIGHT

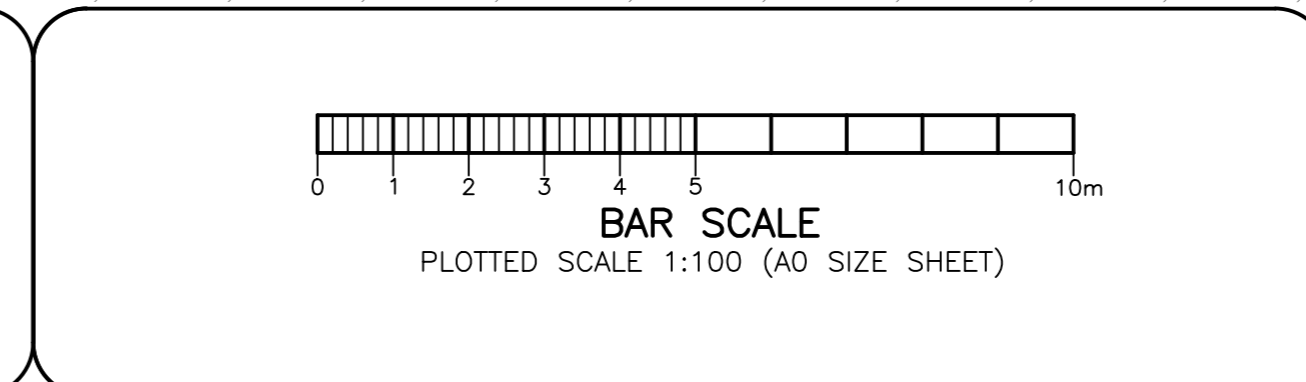

**PLAN SHOWING DETAIL & LEVELS**  
**OVER LOT 1 IN DP 1022436**

CLIENT: NEXT LEVEL UP CONSTRUCTION SERVICES PTY LTD  
PROJECT: CHULLORA  
ADDRESS: 2-34 DAVIDSON ROAD, CHULLORA

JOB No.: 202159	LGA: STRATHFIELD
PLAN No.: 202159-2	DATUM: AHD
DATE: 20/11/2020	SCALE: 1:100@A0
DRAWN: CC	CONT. INTERVAL: 0.25m
CHK: MB	SHEET 5 OF 12



BOUNDARIES HAVE NOT BEEN LOCATED BY SURVEY. THE BOUNDARIES SHOWN ON THIS PLAN HAVE BEEN TAKEN FROM THE TITLE DEPOSITED PLAN AND ARE APPROXIMATE RELATIVE TO THE DETAIL SURVEY.



MGA



**NOTE:**  
THE BOUNDARY INFORMATION SHOWN ON THIS PLAN REGARDING THE LOCATION OF THE PROPERTY BOUNDARIES HAS BEEN TAKEN FROM THE TITLE DEPOSITED PLAN. IT HAS BEEN PLOTTED AS REQUIRED UNDER DIVISION 1, SECTION 9 (1) OF THE 'SURVEYING AND SPATIAL INFORMATION REGULATION 2017' AND IS ACCURATE TO ABOUT 50.0mm. IT HAS NOT BEEN DETERMINED BY AN ACCURATE BOUNDARY SURVEY.

A DETAIL & LEVEL SURVEY IS NOT A 'LAND SURVEY' AS DEFINED BY THE SURVEYING AND SPATIAL INFORMATION ACT, 2002. IF ANY CONSTRUCTION OR DESIGN WORK WHICH RELIES ON CRITICAL SETBACKS FROM THE STREET OR BOUNDARIES IS PLANNED, IT WOULD BE IMPERATIVE TO CARRY OUT FURTHER SURVEY WORK TO DETERMINE THE BOUNDARY DIMENSIONS.

PRIOR TO ANY CONSTRUCTION WORK, SURVEY MARKS SHOULD BE PLACED TO DEFINE THE PROPERTY BOUNDARIES.

SERVICES SHOWN ARE INDICATIVE ONLY. POSITIONS ARE BASED ON SURFACE INDICATOR(S) LOCATED DURING FIELD SURVEY. CONFIRMATION OF THE EXACT POSITION SHOULD BE MADE PRIOR TO ANY EXCAVATION WORK. OTHER SERVICES MAY EXIST WHICH ARE NOT SHOWN.

LEVELS ARE BASED ON AUSTRALIAN HEIGHT DATUM (AHD) USING SSM 61712 WITH RL 29.20 (AHD).

RIDGE & GUTTER HEIGHTS HAVE BEEN OBTAINED BY INDIRECT METHOD AND ARE ACCURATE TO ± 0.05m.

CONTOURS SHOWN DEPICT THE TOPOGRAPHY. EXCEPT AT SPOT LEVELS SHOWN THEY DO NOT REPRESENT THE EXACT LEVEL AT ANY PARTICULAR POINT. THE SPOT LEVELS ARE TRUE FOR THEIR POSITION, AND ARE INTENDED TO BE USEFUL TO REPRESENT THE GENERAL TERRAIN. CARE SHOULD BE TAKEN IF EXTRAPOLATING.

(A) EASEMENT FOR TRANSMISSION LINE VARIABLE WIDTH (S008320)  
(B) PROPOSED EASEMENT FOR UNDERGROUND ELECTRICITY CABLE 1 WIDE (P282926)  
(C) RIGHT OF CARRIAGEWAY VARIABLE WIDTH  
(D) EASEMENT FOR ELECTRICITY PURPOSES 5.0 WIDE AND VARIABLE.

ADDITIONAL TREES THAT FALL WITHIN THE DENOTED TREE QUADRANTS ARE REFERRED TO IN THE TREE QUADRANT REPORT No: 202159-5.

2  
73808

**STRATHFIELD COUNCIL RECEIVED**  
**S8.2 DA2021.52**  
**DATE 3 February 2022**

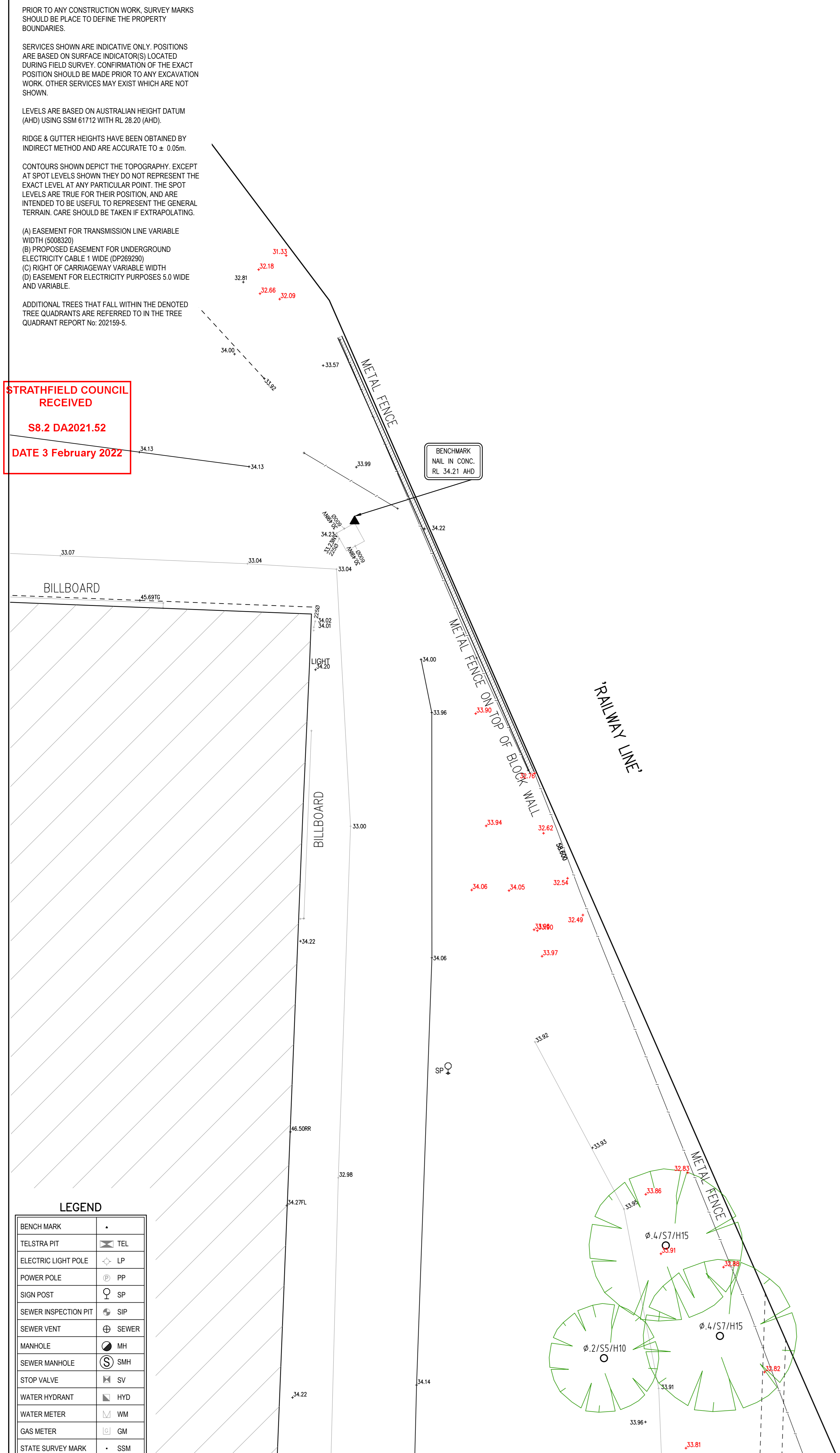

**LEGEND**

BENCH MARK	•
TELSTRA PIT	TEL
ELECTRIC LIGHT POLE	LP
POWER POLE	PP
SIGN POST	SP
SEWER INSPECTION PIT	SIP
SEWER VENT	SEWER
MANHOLE	MH
SEWER MANHOLE	SMH
STOP VALVE	SV
WATER HYDRANT	HYD
WATER METER	WM
GAS METER	GM
STATE SURVEY MARK	SSM

**NOTE:**  
INFORMATION CONTAINED IN THIS PLAN IS THE COPYRIGHT OF TOTAL SURVEYING SOLUTIONS. THE USE OR DUPLICATION WITHOUT THE WRITTEN CONSENT OF TOTAL SURVEYING SOLUTIONS CONSTITUTES AN INFRINGEMENT OF COPYRIGHT.

REVISION No.	REVISION DATE:	COMMENT:
2	25/11/2020	ADDITIONAL STORMWATER INVERT ADDED AND UPDATE DRAFTING
3	11/02/2021	EXTRA LEVELS AROUND BOUNDARY
4	04/05/2021	UPDATE SUFFIXES DENOTING ROOF RIDGES, GUTTERS AND AWNINGS
5	12/07/2021	ADD TREES ADJACENT TO THE SOUTHERN BOUNDARY

**LEGEND:**

EB - EDGE OF BITUMEN	TG - TOP OF GUTTER
EC - EDGE OF CONCRETE	RR - ROOF RIDGE
TB - TOP OF BANK	FL - FLOOR LEVEL
BB - BOTTOM OF BANK	INV - INVERT LEVEL
TW - TOP OF WINDOW	ELEC - ELECTRICAL PIT
AWN - TOP OF AWNING	Ø.4/S10/H16 - DIAMETER/SPREAD/HEIGHT

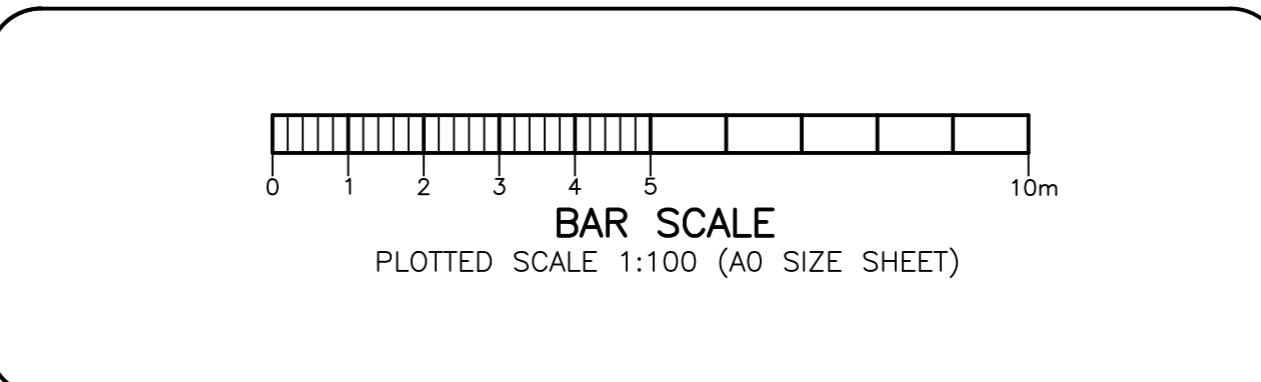

**PLAN SHOWING DETAIL & LEVELS**  
**OVER LOT 1 IN DP 1022436**

CLIENT: NEXT LEVEL UP CONSTRUCTION SERVICES PTY LTD  
PROJECT: CHULLORA  
ADDRESS: 2-34 DAVIDSON ROAD, CHULLORA

JOB No.: 202159	LGA: STRATHFIELD
PLAN No.: 202159-2	DATUM: AHD
DATE: 20/11/2020	SCALE: 1:100@A0
DRAWN: CC	CONT. INTERVAL: 0.25m
CHK: MB	SHEET 6 OF 12





**NOTE:**  
 THE BOUNDARY INFORMATION SHOWN ON THIS PLAN REGARDING THE LOCATION OF THE PROPERTY BOUNDARIES HAS BEEN TAKEN FROM THE TITLE DEPOSITED PLAN. IT HAS BEEN PLOTTED AS REQUIRED UNDER DIVISION 1, SECTION 9(1) OF THE 'SURVEYING AND SPATIAL INFORMATION REGULATION 2017' AND IS ACCURATE TO ABOUT 50.0mm. IT HAS NOT BEEN DETERMINED BY AN ACCURATE BOUNDARY SURVEY.

A DETAIL & LEVEL SURVEY IS NOT A 'LAND SURVEY' AS DEFINED BY THE SURVEYING AND SPATIAL INFORMATION ACT, 2002. IF ANY CONSTRUCTION OR DESIGN WORK WHICH RELIES ON CRITICAL SETBACKS FROM THE STREET OR BOUNDARIES IS PLANNED, IT WOULD BE IMPERATIVE TO CARRY OUT FURTHER SURVEY WORK TO DETERMINE THE BOUNDARY DIMENSIONS.

PRIOR TO ANY CONSTRUCTION WORK, SURVEY MARKS SHOULD BE PLACED TO DEFINE THE PROPERTY BOUNDARIES.

SERVICES SHOWN ARE INDICATIVE ONLY. POSITIONS ARE BASED ON SURFACE INDICATOR(S) LOCATED DURING FIELD SURVEY. CONFIRMATION OF THE EXACT POSITION SHOULD BE MADE PRIOR TO ANY EXCAVATION WORK. OTHER SERVICES MAY EXIST WHICH ARE NOT SHOWN.

LEVELS ARE BASED ON AUSTRALIAN HEIGHT DATUM (AHD) USING SSM 67112 WITH RL 29.20 (AHD).

RIDGE & GUTTER HEIGHTS HAVE BEEN OBTAINED BY INDIRECT METHOD AND ARE ACCURATE TO ± 0.05m.

CONTOURS SHOWN DEPICT THE TOPOGRAPHY EXCEPT AT SPOT LEVELS SHOWN THEY DO NOT REPRESENT THE EXACT LEVEL AT ANY PARTICULAR POINT. THE SPOT LEVELS ARE TRUE FOR THEIR POSITION, AND ARE INTENDED TO BE USEFUL TO REPRESENT THE GENERAL TERRAIN. CARE SHOULD BE TAKEN IF EXTRAPOLATING.

(A) EASEMENT FOR TRANSMISSION LINE VARIABLE WIDTH (500820)  
 (B) PROPOSED EASEMENT FOR UNDERGROUND ELECTRICITY CABLE 1 WIDE (DP202290)  
 (C) RIGHT OF CARRIAGEWAY VARIABLE WIDTH  
 (D) EASEMENT FOR ELECTRICITY PURPOSES 5.0 WIDE AND VARIABLE.

ADDITIONAL TREES THAT FALL WITHIN THE DENOTED TREE QUADRANTS ARE REFERRED TO IN THE TREE QUADRANT REPORT No. 202159-5.

**STRATHFIELD COUNCIL RECEIVED**

**S8.2 DA2021.52**

**DATE 3 February 2022**

BOUNDARIES HAVE NOT BEEN LOCATED BY SURVEY. THE BOUNDARIES SHOWN ON THIS PLAN HAVE BEEN TAKEN FROM THE TITLE DEPOSITED PLAN AND ARE APPROXIMATE RELATIVE TO THE DETAIL SURVEY.

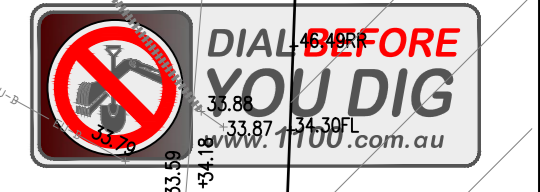

**LEGEND**

BENCH MARK	•
TELSTRA PIT	TEL
ELECTRIC LIGHT POLE	LP
POWER POLE	PP
SIGN POST	SP
SEWER INSPECTION PIT	SIP
SEWER VENT	SV
MANHOLE	MH
SEWER MANHOLE	SMH
STOP VALVE	SV
WATER HYDRANT	HYD
WATER METER	WM
GAS METER	GM
STATE SURVEY MARK	SSM

**NOTE:**  
 INFORMATION CONTAINED IN THIS PLAN IS THE COPYRIGHT OF TOTAL SURVEYING SOLUTIONS. THE USE OR DUPLICATION WITHOUT THE WRITTEN CONSENT OF TOTAL SURVEYING SOLUTIONS CONSTITUTES AN INFRINGEMENT OF COPYRIGHT.

REVISION No.	REVISION DATE:	COMMENT:
2	25/11/2020	ADDITIONAL STORMWATER INVERT ADDED AND UPDATE DRAFTING
3	11/02/2021	EXTRA LEVELS AROUND BOUNDARY
4	04/05/2021	UPDATE SUFFIXES DENOTING ROOF RIDGES, GUTTERS AND AWNINGS
5	12/07/2021	ADD TREES ADJACENT TO THE SOUTHERN BOUNDARY

**LEGEND:**

EB - EDGE OF BITUMEN	TG - TOP OF GUTTER
EC - EDGE OF CONCRETE	RR - ROOF RIDGE
EX - EXTRA LEVELS AROUND BOUNDARY	FL - FLOOR LEVEL
TB - TOP OF BANK	INV - INVERT LEVEL
BB - BOTTOM OF BANK	ELEC - ELECTRICAL PIT
TW - TOP OF WINDOW	Ø.4/S10/H16 - DIAMETER/SPREAD/HEIGHT
AWN - TOP OF AWNING	

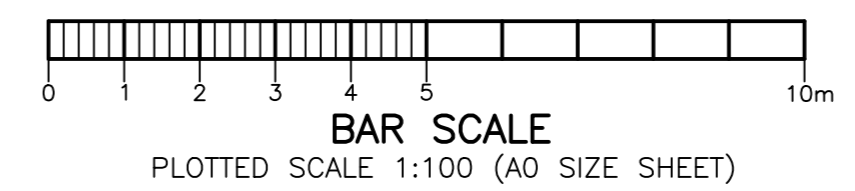

**PLAN SHOWING DETAIL & LEVELS**  
**OVER LOT 1 IN DP 1022436**

CLIENT: NEXT LEVEL UP CONSTRUCTION SERVICES PTY LTD  
 PROJECT: CHULLORA  
 ADDRESS: 2-34 DAVIDSON ROAD, CHULLORA

JOB No.: 202159	LGA: STRATHFIELD
PLAN No.: 202159-2	DATUM: AHD
DATE: 20/11/2020	SCALE: 1:100@A0
DRAWN: CC	CONT. INTERVAL: 0.25m
CHK: MB	SHEET 7 OF 12



**NOTE:**

THE BOUNDARY INFORMATION SHOWN ON THIS PLAN REGARDING THE LOCATION OF THE PROPERTY BOUNDARIES HAS BEEN TAKEN FROM THE TITLE DEPOSITED PLAN. IT HAS BEEN PLOTTED AS REQUIRED UNDER DIVISION 1, SECTION 9 (1) OF THE 'SURVEYING AND SPATIAL INFORMATION REGULATION 2017' AND IS ACCURATE TO ABOUT 20.0mm. IT HAS NOT BEEN DETERMINED BY AN ACCURATE BOUNDARY SURVEY.

A DETAIL & LEVEL SURVEY IS NOT A 'LAND SURVEY' AS DEFINED BY THE SURVEYING AND SPATIAL INFORMATION ACT, 2002. IF ANY CONSTRUCTION OR DESIGN WORK WHICH RELIES ON CRITICAL SETBACKS FROM THE STREET OR BOUNDARIES IS PLANNED, IT WOULD BE IMPERATIVE TO CARRY OUT FURTHER SURVEY WORK TO DETERMINE THE BOUNDARY DIMENSIONS.

PRIOR TO ANY CONSTRUCTION WORK, SURVEY MARKS SHOULD BE PLACED TO DEFINE THE PROPERTY BOUNDARIES.

SERVICES SHOWN ARE INDICATIVE ONLY. POSITIONS ARE BASED ON SURFACE INDICATOR(S) LOCATED DURING FIELD SURVEY. CONFIRMATION OF THE EXACT POSITION SHOULD BE MADE PRIOR TO ANY EXCAVATION WORK. OTHER SERVICES MAY EXIST WHICH ARE NOT SHOWN.

LEVELS ARE BASED ON AUSTRALIAN HEIGHT DATUM (AHD) USING SSM 67112 WITH RL 29.20 (AHD).

RIDGE & GUTTER HEIGHTS HAVE BEEN OBTAINED BY INDIRECT METHOD AND ARE ACCURATE TO ± 0.05m.

CONTOURS SHOWN DEPICT THE TOPOGRAPHY. EXCEPT AT SPOT LEVELS SHOWN THEY DO NOT REPRESENT THE EXACT LEVEL AT ANY PARTICULAR POINT. THE SPOT LEVELS ARE TRUE FOR THEIR POSITION, AND ARE INTENDED TO BE USEFUL TO REPRESENT THE GENERAL TERRAIN. CARE SHOULD BE TAKEN IF EXTRAPOLATING.

- (A) EASEMENT FOR TRANSMISSION LINE VARIABLE WIDTH (S008320)
- (B) PROPOSED EASEMENT FOR UNDERGROUND ELECTRICITY CABLE 1 MIDE (D002290)
- (C) RIGHT OF CARRIAGEWAY VARIABLE WIDTH
- (D) EASEMENT FOR ELECTRICITY PURPOSES 5.0 WIDE AND VARIABLE.

ADDITIONAL TREES THAT FALL WITHIN THE DENOTED TREE QUADRANTS ARE REFERRED TO IN THE TREE QUADRANT REPORT No. 202159-5.

BOUNDARIES HAVE NOT BEEN LOCATED BY SURVEY. THE BOUNDARIES SHOWN ON THIS PLAN HAVE BEEN TAKEN FROM THE TITLE DEPOSITED PLAN AND ARE APPROXIMATE RELATIVE TO THE DETAIL SURVEY.



MGA

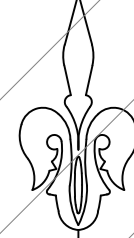

STRATHFIELD COUNCIL  
RECEIVED  
S8.2 DA2021.52  
DATE 3 February 2022

MULTI STOREY  
CONCRETE WAREHOUSE  
(METAL ROOF)  
No.2-34

**LEGEND**

BENCH MARK	•
TELSTRA PIT	TEL
ELECTRIC LIGHT POLE	LP
POWER POLE	PP
SIGN POST	SP
SEWER INSPECTION PIT	SIP
SEWER VENT	SEWER
MANHOLE	MH
SEWER MANHOLE	SMH
STOP VALVE	SV
WATER HYDRANT	HYD
WATER METER	WM
GAS METER	GM
STATE SURVEY MARK	SSM



LANE COVE | CAMDEN | MANLY VALE | CENTRAL COAST

**NOTE:**  
INFORMATION CONTAINED IN THIS PLAN IS THE COPYRIGHT OF TOTAL SURVEYING SOLUTIONS. THE USE OR DUPLICATION WITHOUT THE WRITTEN CONSENT OF TOTAL SURVEYING SOLUTIONS CONSTITUTES AN INFRINGEMENT OF COPYRIGHT.

REVISION No.	REVISION DATE:	COMMENT:
2	25/11/2020	ADDITIONAL STORMWATER INVERT ADDED AND UPDATE DRAFTING
3	11/02/2021	EXTRA LEVELS AROUND BOUNDARY
4	04/05/2021	UPDATE SUFFIXES DENOTING ROOF RIDGES, GUTTERS AND AWNINGS
5	12/07/2021	ADD TREES ADJACENT TO THE SOUTHERN BOUNDARY

**LEGEND:**

EB - EDGE OF BITUMEN	TG - TOP OF GUTTER
EC - EDGE OF CONCRETE	RR - ROOF RIDGE
TB - TOP OF BANK	FL - FLOOR LEVEL
BB - BOTTOM OF BANK	INV - INVERT LEVEL
TW - TOP OF WINDOW	ELEC - ELECTRICAL PIT
AWN - TOP OF AWNING	Ø.4/S10/H16 - DIAMETER/SPREAD/HEIGHT

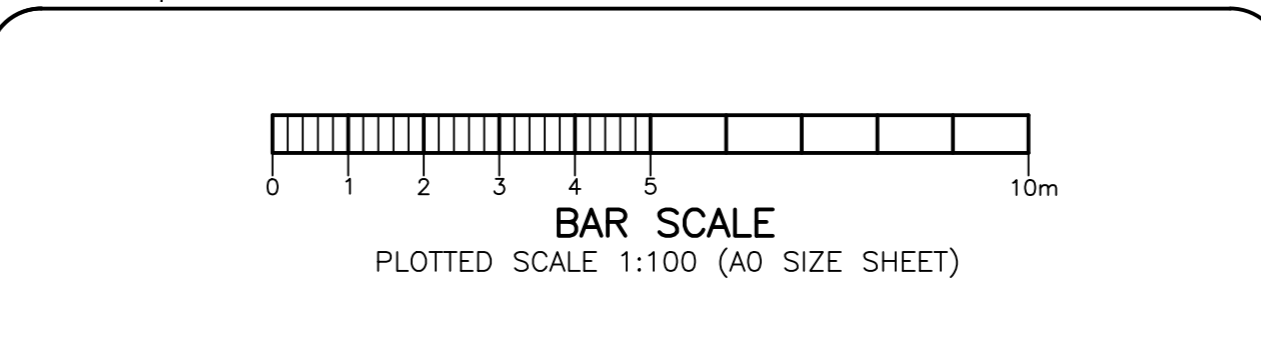

**PLAN SHOWING DETAIL & LEVELS**  
**OVER LOT 1 IN DP 1022436**

CLIENT: NEXT LEVEL UP CONSTRUCTION SERVICES PTY LTD  
PROJECT: CHULLORA  
ADDRESS: 2-34 DAVIDSON ROAD, CHULLORA

JOB No.: 202159	LGA: STRATHFIELD
PLAN No.: 202159-2	DATUM: AHD
DATE: 20/11/2020	SCALE: 1:100@A0
DRAWN: CC	CONT. INTERVAL: 0.25m
CHK: MB	SHEET 8 OF 12



BOUNDARIES HAVE NOT BEEN LOCATED BY SURVEY. THE BOUNDARIES SHOWN ON THIS PLAN HAVE BEEN TAKEN FROM THE TITLE DEPOSITED PLAN AND ARE APPROXIMATE RELATIVE TO THE DETAIL SURVEY.

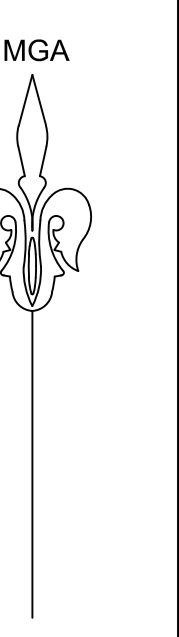

**NOTE:**  
THE BOUNDARY INFORMATION SHOWN ON THIS PLAN REGARDING THE LOCATION OF THE PROPERTY BOUNDARIES HAS BEEN TAKEN FROM THE TITLE DEPOSITED PLAN. IT HAS BEEN PLOTTED AS REQUIRED UNDER DIVISION 1, SECTION 9(1) OF THE 'SURVEYING AND SPATIAL INFORMATION REGULATION 2017' AND IS ACCURATE TO ABOUT 30.0mm. IT HAS NOT BEEN DETERMINED BY AN ACCURATE BOUNDARY SURVEY.

A DETAIL & LEVEL SURVEY IS NOT A 'LAND SURVEY' AS DEFINED BY THE SURVEYING AND SPATIAL INFORMATION ACT, 2002. IF ANY CONSTRUCTION OR DESIGN WORK WHICH RELIES ON CRITICAL SETBACKS FROM THE STREET OR BOUNDARIES IS PLANNED, IT WOULD BE IMPERATIVE TO CARRY OUT FURTHER SURVEY WORK TO DETERMINE THE BOUNDARY DIMENSIONS.

PRIOR TO ANY CONSTRUCTION WORK, SURVEY MARKS SHOULD BE PLACED TO DEFINE THE PROPERTY BOUNDARIES.

SERVICES SHOWN ARE INDICATIVE ONLY. POSITIONS ARE BASED ON SURFACE INDICATOR(S) LOCATED DURING FIELD SURVEY. CONFIRMATION OF THE EXACT POSITION SHOULD BE MADE PRIOR TO ANY EXCAVATION WORK. OTHER SERVICES MAY EXIST WHICH ARE NOT SHOWN.

LEVELS ARE BASED ON AUSTRALIAN HEIGHT DATUM (AHD) USING SSM 67112 WITH RL 29.20 (AHD).

RIDGE & GUTTER HEIGHTS HAVE BEEN OBTAINED BY INDIRECT METHOD AND ARE ACCURATE TO ± 0.05m.

CONTOURS SHOWN DEPICT THE TOPOGRAPHY EXCEPT AT SPOT LEVELS SHOWN THEY DO NOT REPRESENT THE EXACT LEVEL AT ANY PARTICULAR POINT. THE SPOT LEVELS ARE TRUE FOR THEIR POSITION, AND ARE INTENDED TO BE USEFUL TO REPRESENT THE GENERAL TERRAIN. CARE SHOULD BE TAKEN IF EXTRAPOLATING.

(A) EASEMENT FOR TRANSMISSION LINE VARIABLE WIDTH (S008320)  
(B) PROPOSED EASEMENT FOR UNDERGROUND ELECTRICITY CABLE 1 WIDE (DPS02200)  
(C) RIGHT OF CARRIAGEWAY VARIABLE WIDTH  
(D) EASEMENT FOR ELECTRICITY PURPOSES 5.0 WIDE AND VARIABLE.

ADDITIONAL TREES THAT FALL WITHIN THE DENOTED TREE QUADRANTS ARE REFERRED TO IN THE TREE QUADRANT REPORT No. 202159-5.

STRATHFIELD COUNCIL RECEIVED  
S8.2 DA2021.52  
DATE 3 February 2022

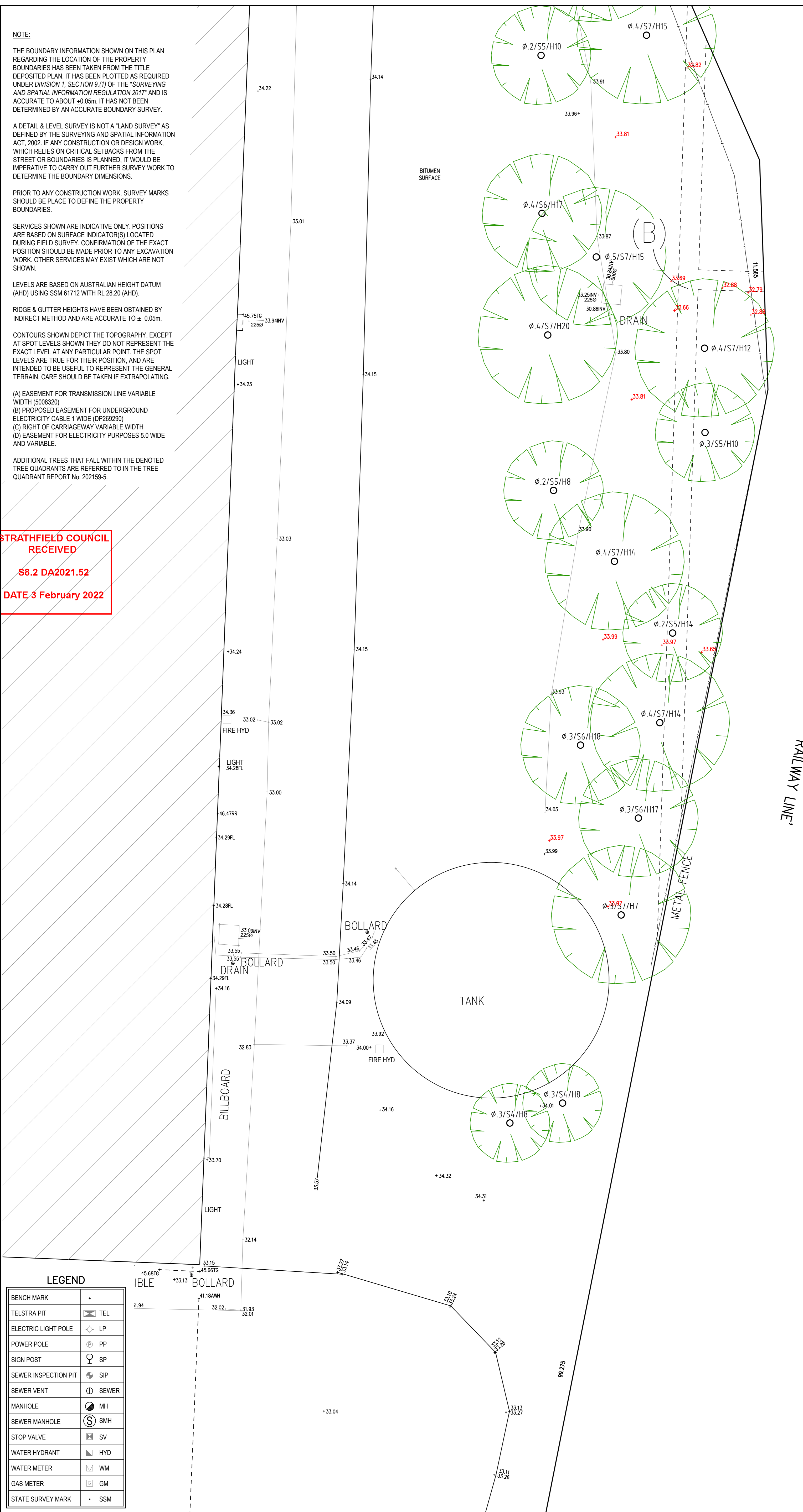

**LEGEND**

BENCH MARK	•
TELSTRA PIT	TEL
ELECTRIC LIGHT POLE	LP
POWER POLE	PP
SIGN POST	SP
SEWER INSPECTION PIT	SIP
SEWER VENT	SEWER
MANHOLE	MH
SEWER MANHOLE	SMH
STOP VALVE	SV
WATER HYDRANT	HYD
WATER METER	WM
GAS METER	GM
STATE SURVEY MARK	SSM



**NOTE:**  
INFORMATION CONTAINED IN THIS PLAN IS THE COPYRIGHT OF TOTAL SURVEYING SOLUTIONS. THE USE OR DUPLICATION WITHOUT THE WRITTEN CONSENT OF TOTAL SURVEYING SOLUTIONS CONSTITUTES AN INFRINGEMENT OF COPYRIGHT.

REVISION No.	REVISION DATE:	COMMENT:
2	25/11/2020	ADDITIONAL STORMWATER INVERT ADDED AND UPDATE DRAFTING
3	11/02/2021	EXTRA LEVELS AROUND BOUNDARY
4	04/05/2021	UPDATE SUFFIXES DENOTING ROOF RIDGES, GUTTERS AND AWNINGS
5	12/07/2021	ADD TREES ADJACENT TO THE SOUTHERN BOUNDARY

**LEGEND:**

EB - EDGE OF BITUMEN	TG - TOP OF GUTTER
EC - EDGE OF CONCRETE	RR - ROOF RIDGE
EXTRA LEVELS AROUND BOUNDARY	FL - FLOOR LEVEL
BB - BOTTOM OF BANK	INV - INVERT LEVEL
TW - TOP OF WINDOW	ELEC - ELECTRICAL PIT
AWN - TOP OF AWNING	Ø.4/S10/H16 - DIAMETER/SPREAD/HEIGHT

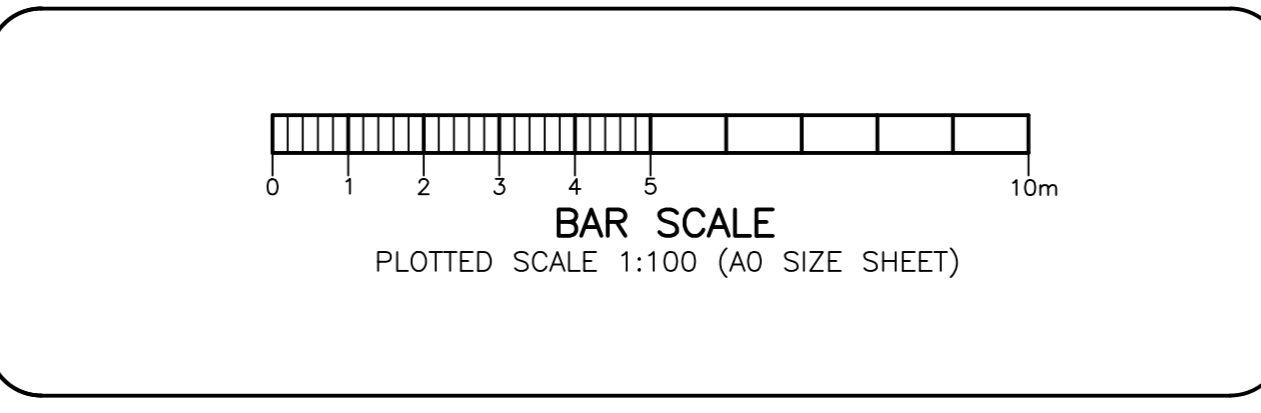

**PLAN SHOWING DETAIL & LEVELS**  
**OVER LOT 1 IN DP 1022436**

CLIENT: NEXT LEVEL UP CONSTRUCTION SERVICES PTY LTD  
PROJECT: CHULLORA  
ADDRESS: 2-34 DAVIDSON ROAD, CHULLORA

JOB No.: 202159	LGA: STRATHFIELD
PLAN No.: 202159-2	DATUM: AHD
DATE: 20/11/2020	SCALE: 1:100@A0
DRAWN: CC	CONT. INTERVAL: 0.25m
CHK: MB	SHEET 9 OF 12



**NOTE:**

THE BOUNDARY INFORMATION SHOWN ON THIS PLAN REGARDING THE LOCATION OF THE PROPERTY BOUNDARIES HAS BEEN TAKEN FROM THE TITLE DEPOSITED PLAN. IT HAS BEEN PLOTTED AS REQUIRED UNDER DIVISION 1, SECTION 9 (1) OF THE 'SURVEYING AND SPATIAL INFORMATION REGULATION 2017' AND IS ACCURATE TO ABOUT 50/100. IT HAS NOT BEEN DETERMINED BY AN ACCURATE BOUNDARY SURVEY.

A DETAIL & LEVEL SURVEY IS NOT A 'LAND SURVEY' AS DEFINED BY THE SURVEYING AND SPATIAL INFORMATION ACT, 2002. IF ANY CONSTRUCTION OR DESIGN WORK WHICH RELIES ON CRITICAL SETBACKS FROM THE STREET OR BOUNDARIES IS PLANNED, IT WOULD BE IMPERATIVE TO CARRY OUT FURTHER SURVEY WORK TO DETERMINE THE BOUNDARY DIMENSIONS.

PRIOR TO ANY CONSTRUCTION WORK, SURVEY MARKS SHOULD BE PLACED TO DEFINE THE PROPERTY BOUNDARIES.

SERVICES SHOWN ARE INDICATIVE ONLY. POSITIONS ARE BASED ON SURFACE INDICATOR(S) LOCATED DURING FIELD SURVEY. CONFIRMATION OF THE EXACT POSITION SHOULD BE MADE PRIOR TO ANY EXCAVATION WORK. OTHER SERVICES MAY EXIST WHICH ARE NOT SHOWN.

LEVELS ARE BASED ON AUSTRALIAN HEIGHT DATUM (AHD) USING SSM 61712 WITH RL 29.20 (AHD).

RIDGE & GUTTER HEIGHTS HAVE BEEN OBTAINED BY INDIRECT METHOD AND ARE ACCURATE TO ± 0.05m.

CONTOURS SHOWN DEPICT THE TOPOGRAPHY EXCEPT AT SPOT LEVELS SHOWN THEY DO NOT REPRESENT THE EXACT LEVEL AT ANY PARTICULAR POINT. THE SPOT LEVELS ARE TRUE FOR THEIR POSITION, AND ARE INTENDED TO BE USEFUL TO REPRESENT THE GENERAL TERRAIN. CARE SHOULD BE TAKEN IF EXTRAPOLATING.

- (A) EASEMENT FOR TRANSMISSION LINE VARIABLE WIDTH (508320)
- (B) PROPOSED EASEMENT FOR UNDERGROUND ELECTRICITY CABLE 1 WIDE (DPS02296)
- (C) RIGHT OF CARRIAGEWAY VARIABLE WIDTH
- (D) EASEMENT FOR ELECTRICITY PURPOSES 5.0 WIDE AND VARIABLE.

ADDITIONAL TREES THAT FALL WITHIN THE DENOTED TREE QUADRANTS ARE REFERRED TO IN THE TREE QUADRANT REPORT No. 202159-5.

BOUNDARIES HAVE NOT BEEN LOCATED BY SURVEY. THE BOUNDARIES SHOWN ON THIS PLAN HAVE BEEN TAKEN FROM THE TITLE DEPOSITED PLAN AND ARE APPROXIMATE RELATIVE TO THE DETAIL SURVEY.



**STRATHFIELD COUNCIL RECEIVED**  
 S8.2 DA2021.52  
 DATE 3 February 2022

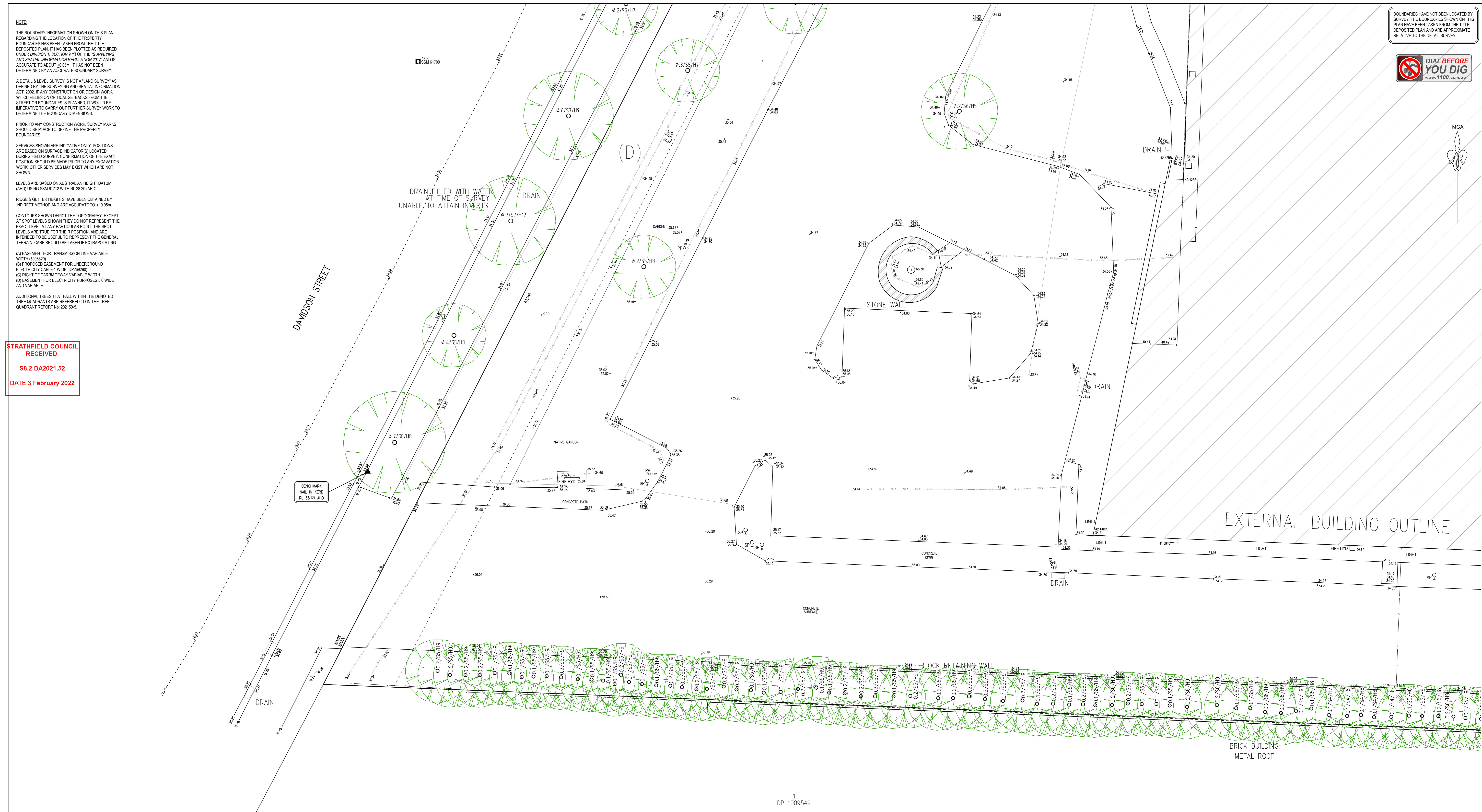

**LEGEND**

BENCHMARK	•
TELSTRA PIT	TEL
ELECTRIC LIGHT POLE	LP
POWER POLE	PP
SIGN POST	SP
SEWER INSPECTION PIT	SIP
SEWER VENT	SEWER
MANHOLE	MH
SEWER MANHOLE	SMH
STOP VALVE	SV
WATER HYDRANT	HYD
WATER METER	WM
GAS METER	GM
STATE SURVEY MARK	SSM

**NOTE:**  
 INFORMATION CONTAINED IN THIS PLAN IS THE COPYRIGHT OF TOTAL SURVEYING SOLUTIONS. THE USE OR DUPLICATION WITHOUT THE WRITTEN CONSENT OF TOTAL SURVEYING SOLUTIONS CONSTITUTES AN INFRINGEMENT OF COPYRIGHT.

REVISION No.	REVISION DATE:	COMMENT:
2	25/11/2020	ADDITIONAL STORMWATER INVERT ADDED AND UPDATE DRAFTING
3	11/02/2021	EXTRA LEVELS AROUND BOUNDARY
4	04/05/2021	UPDATE SUFFIXES DENOTING ROOF RIDGES, GUTTERS AND AWNINGS
5	12/07/2021	ADD TREES ADJACENT TO THE SOUTHERN BOUNDARY

**LEGEND:**

EB - EDGE OF BITUMEN	TG - TOP OF GUTTER
EC - EDGE OF CONCRETE	RR - ROOF RIDGE
TB - TOP OF BANK	FL - FLOOR LEVEL
BB - BOTTOM OF BANK	INV - INVERT LEVEL
TW - TOP OF WINDOW	ELEC - ELECTRICAL PIT
AWN - TOP OF AWNING	Ø.4/S10/H16 - DIAMETER/SPREAD/HEIGHT

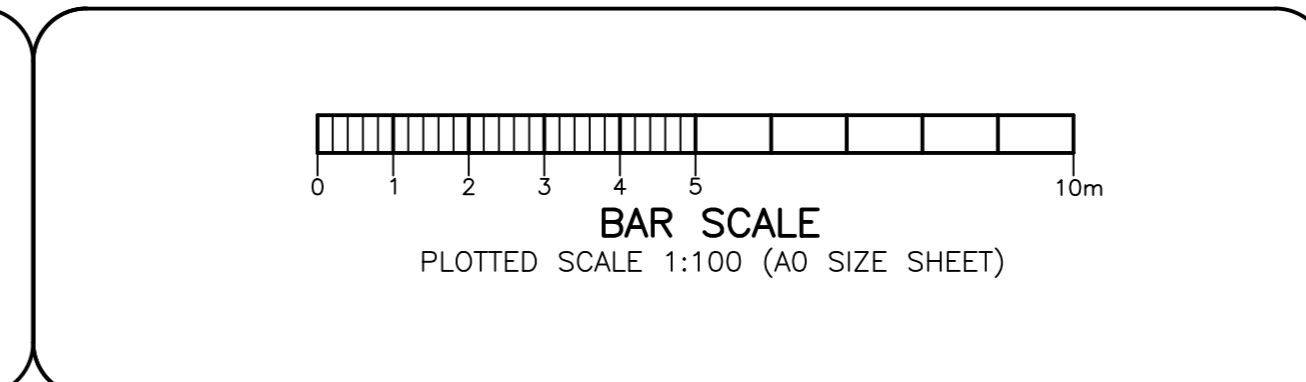

**PLAN SHOWING DETAIL & LEVELS**  
 OVER LOT 1 IN DP 1022436

CLIENT: NEXT LEVEL UP CONSTRUCTION SERVICES PTY LTD  
 PROJECT: CHULLORA  
 ADDRESS: 2-34 DAVIDSON ROAD, CHULLORA

JOB No.: 202159	LGA: STRATHFIELD
PLAN No.: 202159-2	DATUM: AHD
DATE: 20/11/2020	SCALE: 1:100@A0
DRAWN: CC	CONT. INTERVAL: 0.25m
CHK: MB	SHEET 10 OF 12



**NOTE:**

THE BOUNDARY INFORMATION SHOWN ON THIS PLAN REGARDING THE LOCATION OF THE PROPERTY BOUNDARIES HAS BEEN TAKEN FROM THE TITLE DEPOSITED PLAN. IT HAS BEEN PLOTTED AS REQUIRED UNDER DIVISION 1, SECTION 9(1) OF THE 'SURVEYING AND SPATIAL INFORMATION REGULATION 2017' AND IS ACCURATE TO ABOUT ±0.05m. IT HAS NOT BEEN DETERMINED BY AN ACCURATE BOUNDARY SURVEY.

A DETAIL & LEVEL SURVEY IS NOT A 'LAND SURVEY' AS DEFINED BY THE SURVEYING AND SPATIAL INFORMATION ACT, 2002. IF ANY CONSTRUCTION OR DESIGN WORK WHICH RELIES ON CRITICAL SETBACKS FROM THE STREET OR BOUNDARIES IS PLANNED, IT WOULD BE IMPERATIVE TO CARRY OUT FURTHER SURVEY WORK TO DETERMINE THE BOUNDARY DIMENSIONS.

PRIOR TO ANY CONSTRUCTION WORK, SURVEY MARKS SHOULD BE PLACED TO DEFINE THE PROPERTY BOUNDARIES.

SERVICES SHOWN ARE INDICATIVE ONLY. POSITIONS ARE BASED ON SURFACE INDICATOR(S) LOCATED DURING FIELD SURVEY. CONFIRMATION OF THE EXACT POSITION SHOULD BE MADE PRIOR TO ANY EXCAVATION WORK. OTHER SERVICES MAY EXIST WHICH ARE NOT SHOWN.

LEVELS ARE BASED ON AUSTRALIAN HEIGHT DATUM (AHD) USING SSM 6712 WITH RL 29.20 (AHD).

RIDGE & GUTTER HEIGHTS HAVE BEEN OBTAINED BY INDIRECT METHOD AND ARE ACCURATE TO ± 0.05m.

CONTOURS SHOWN DEPICT THE TOPOGRAPHY EXCEPT AT SPOT LEVELS SHOWN THEY DO NOT REPRESENT THE EXACT LEVEL AT ANY PARTICULAR POINT. THE SPOT LEVELS ARE TRUE FOR THEIR POSITION, AND ARE INTENDED TO BE USEFUL TO REPRESENT THE GENERAL TERRAIN. CARE SHOULD BE TAKEN IF EXTRAPOLATING.

- (A) EASEMENT FOR TRANSMISSION LINE VARIABLE WIDTH (5008320)
- (B) PROPOSED EASEMENT FOR UNDERGROUND ELECTRICITY CABLE 1 WIDE (DPS02090)
- (C) RIGHT OF CARRIAGEWAY VARIABLE WIDTH
- (D) EASEMENT FOR ELECTRICITY PURPOSES 5.0 WIDE AND VARIABLE.

ADDITIONAL TREES THAT FALL WITHIN THE DENOTED TREE QUADRANTS ARE REFERRED TO IN THE TREE QUADRANT REPORT No. 202159-5.

BOUNDARIES HAVE NOT BEEN LOCATED BY SURVEY. THE BOUNDARIES SHOWN ON THIS PLAN HAVE BEEN TAKEN FROM THE TITLE DEPOSITED PLAN AND ARE APPROXIMATE RELATIVE TO THE DETAIL SURVEY.



STRATHFIELD COUNCIL RECEIVED  
S8.2 DA2021.52  
DATE 3 February 2022

L BUILDING OUTLINE



**LEGEND**

BENCH MARK	•
TELSTRA PIT	TEL
ELECTRIC LIGHT POLE	LP
POWER POLE	PP
SIGN POST	SP
SEWER INSPECTION PIT	SIP
SEWER VENT	SEWER
MANHOLE	MH
SEWER MANHOLE	SMH
STOP VALVE	SV
WATER HYDRANT	HYD
WATER METER	WM
GAS METER	GM
STATE SURVEY MARK	SSM

**NOTE:**  
INFORMATION CONTAINED IN THIS PLAN IS THE COPYRIGHT OF TOTAL SURVEYING SOLUTIONS. THE USE OR DUPLICATION WITHOUT THE WRITTEN CONSENT OF TOTAL SURVEYING SOLUTIONS CONSTITUTES AN INFRINGEMENT OF COPYRIGHT.

REVISION No.	REVISION DATE:	COMMENT:
2	25/11/2020	ADDITIONAL STORMWATER INVERT ADDED AND UPDATE DRAFTING
3	11/02/2021	EXTRA LEVELS AROUND BOUNDARY
4	04/05/2021	UPDATE SUFFIXES DENOTING ROOF RIDGES, GUTTERS AND AWNINGS
5	12/07/2021	ADD TREES ADJACENT TO THE SOUTHERN BOUNDARY

**LEGEND:**

EB - EDGE OF BITUMEN	TG - TOP OF GUTTER
EC - EDGE OF CONCRETE	RR - ROOF RIDGE
TB - TOP OF BANK	FL - FLOOR LEVEL
BB - BOTTOM OF BANK	INV - INVERT LEVEL
TW - TOP OF WINDOW	ELEC - ELECTRICAL PIT
AWN - TOP OF AWNING	Ø.4/S10/H16 - DIAMETER/SPREAD/HEIGHT

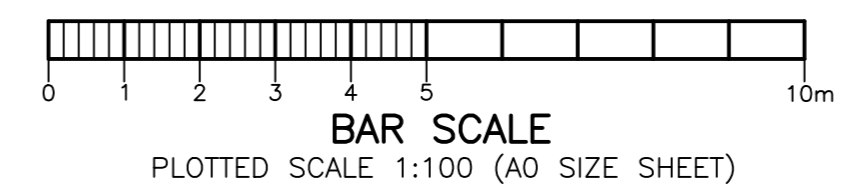

PLAN SHOWING DETAIL & LEVELS OVER LOT 1 IN DP 1022436		JOB No.: 202159	LGA: STRATHFIELD
CLIENT: NEXT LEVEL UP CONSTRUCTION SERVICES PTY LTD	DATE: 20/11/2020	PLAN No.: 202159-2	DATUM: AHD
PROJECT: CHULLORA	SCALE: 1:100@A0	DRAWN: CC	CONT. INTERVAL: 0.25m
ADDRESS: 2-34 DAVIDSON ROAD, CHULLORA	CHK: MB	SHEET 11 OF 12	



**NOTE:**

THE BOUNDARY INFORMATION SHOWN ON THIS PLAN REGARDING THE LOCATION OF THE PROPERTY BOUNDARIES HAS BEEN TAKEN FROM THE TITLE DEPOSITED PLAN. IT HAS BEEN PLOTTED AS REQUIRED UNDER DIVISION 1, SECTION 9 (1) OF THE 'SURVEYING AND SPATIAL INFORMATION REGULATION 2017' AND IS ACCURATE TO ABOUT 0.05m. IT HAS NOT BEEN DETERMINED BY AN ACCURATE BOUNDARY SURVEY.

A DETAIL & LEVEL SURVEY IS NOT A 'LAND SURVEY' AS DEFINED BY THE SURVEYING AND SPATIAL INFORMATION ACT, 2002. IF ANY CONSTRUCTION OR DESIGN WORK WHICH RELIES ON CRITICAL SETBACKS FROM THE STREET OR BOUNDARIES IS PLANNED, IT WOULD BE IMPERATIVE TO CARRY OUT FURTHER SURVEY WORK TO DETERMINE THE BOUNDARY DIMENSIONS.

PRIOR TO ANY CONSTRUCTION WORK, SURVEY MARKS SHOULD BE PLACED TO DEFINE THE PROPERTY BOUNDARIES.

SERVICES SHOWN ARE INDICATIVE ONLY. POSITIONS ARE BASED ON SURFACE INDICATOR(S) LOCATED DURING FIELD SURVEY. CONFIRMATION OF THE EXACT POSITION SHOULD BE MADE PRIOR TO ANY EXCAVATION WORK. OTHER SERVICES MAY EXIST WHICH ARE NOT SHOWN.

LEVELS ARE BASED ON AUSTRALIAN HEIGHT DATUM (AHD) USING SSM 61112 WITH RL 29.20 (AHD).

RIDGE & GUTTER HEIGHTS HAVE BEEN OBTAINED BY INDIRECT METHOD AND ARE ACCURATE TO ± 0.05m.

CONTOURS SHOWN DEPICT THE TOPOGRAPHY EXCEPT AT SPOT LEVELS SHOWN THEY DO NOT REPRESENT THE EXACT LEVEL AT ANY PARTICULAR POINT. THE SPOT LEVELS ARE TRUE FOR THEIR POSITION, AND ARE INTENDED TO BE USEFUL TO REPRESENT THE GENERAL TERRAIN. CARE SHOULD BE TAKEN IF EXTRAPOLATING.

- (A) EASEMENT FOR TRANSMISSION LINE VARIABLE WIDTH (S008320)
- (B) PROPOSED EASEMENT FOR UNDERGROUND ELECTRICITY CABLE 1 WIDE (D002296)
- (C) RIGHT OF CARRIAGEWAY VARIABLE WIDTH
- (D) EASEMENT FOR ELECTRICITY PURPOSES 5.0 WIDE AND VARIABLE.

ADDITIONAL TREES THAT FALL WITHIN THE DENOTED TREE QUADRANTS ARE REFERRED TO IN THE TREE QUADRANT REPORT No. 202159-5.

BOUNDARIES HAVE NOT BEEN LOCATED BY SURVEY. THE BOUNDARIES SHOWN ON THIS PLAN HAVE BEEN TAKEN FROM THE TITLE DEPOSITED PLAN AND ARE APPROXIMATE RELATIVE TO THE DETAIL SURVEY.

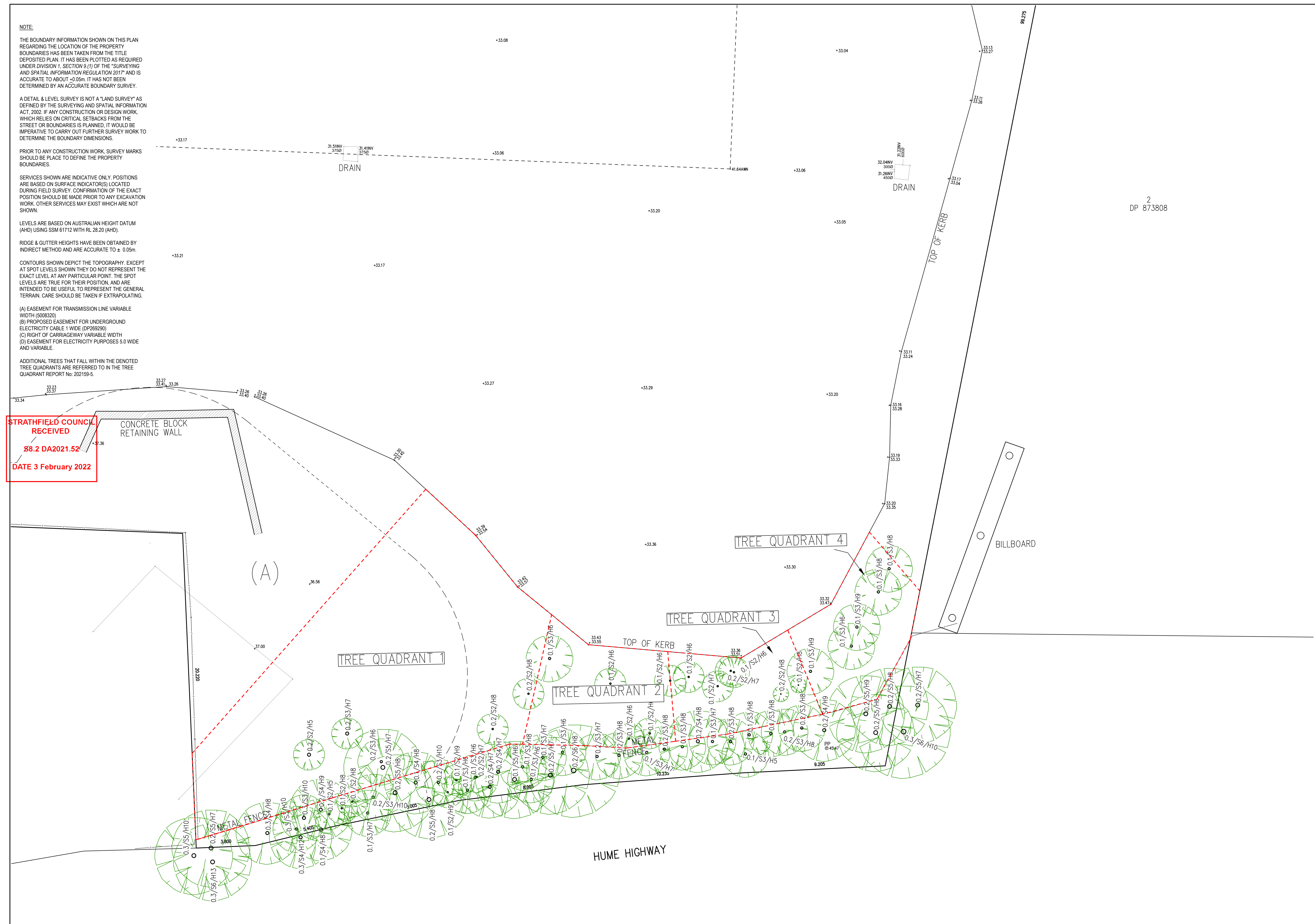
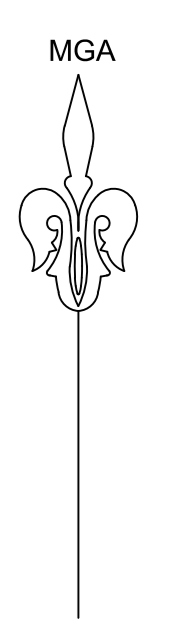

STRATHFIELD COUNCIL RECEIVED  
88.2 DA2021.52  
DATE 3 February 2022

**LEGEND**

BENCH MARK	•
TELSTRA PIT	TEL
ELECTRIC LIGHT POLE	LP
POWER POLE	PP
SIGN POST	SP
SEWER INSPECTION PIT	SIP
SEWER VENT	SEWER
MANHOLE	MH
SEWER MANHOLE	SMH
STOP VALVE	SV
WATER HYDRANT	HYD
WATER METER	WM
GAS METER	GM
STATE SURVEY MARK	SSM

**NOTE:**  
INFORMATION CONTAINED IN THIS PLAN IS THE COPYRIGHT OF TOTAL SURVEYING SOLUTIONS. THE USE OR DUPLICATION WITHOUT THE WRITTEN CONSENT OF TOTAL SURVEYING SOLUTIONS CONSTITUTES AN INFRINGEMENT OF COPYRIGHT.

REVISION No.	REVISION DATE:	COMMENT:
2	25/11/2020	ADDITIONAL STORMWATER INVERT ADDED AND UPDATE DRAFTING
3	11/02/2021	EXTRA LEVELS AROUND BOUNDARY
4	04/05/2021	UPDATE SUFFIXES DENOTING ROOF RIDGES, GUTTERS AND AWNINGS
5	12/07/2021	ADD TREES ADJACENT TO THE SOUTHERN BOUNDARY

**LEGEND:**

EB - EDGE OF BITUMEN	TG - TOP OF GUTTER
EC - EDGE OF CONCRETE	RR - ROOF RIDGE
TB - TOP OF BANK	FL - FLOOR LEVEL
BB - BOTTOM OF BANK	INV - INVERT LEVEL
TW - TOP OF WINDOW	ELEC - ELECTRICAL PIT
AWN - TOP OF AWNING	Ø.4/S10/H16 - DIAMETER/SPREAD/HEIGHT

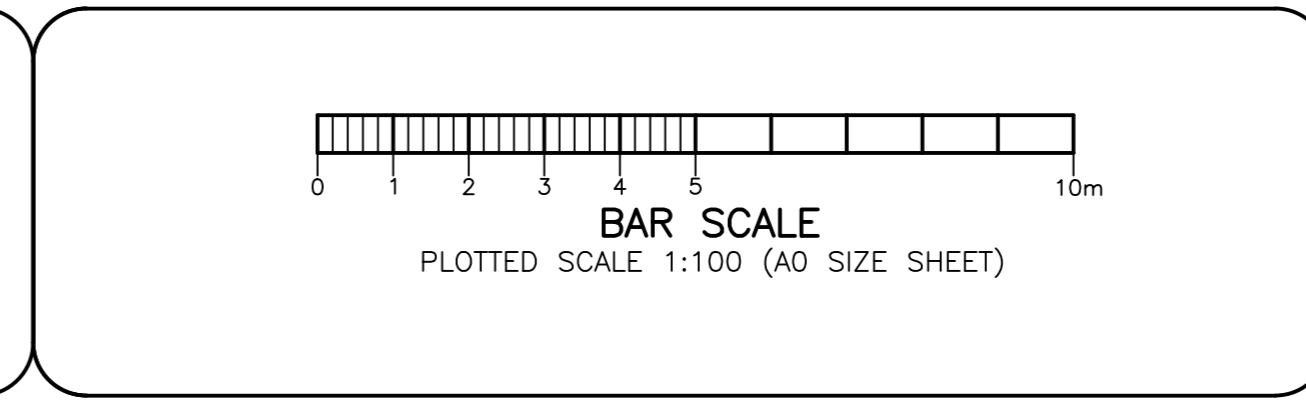

**PLAN SHOWING DETAIL & LEVELS**  
**OVER LOT 1 IN DP 1022436**

CLIENT: NEXT LEVEL UP CONSTRUCTION SERVICES PTY LTD  
PROJECT: CHULLORA  
ADDRESS: 2-34 DAVIDSON ROAD, CHULLORA

JOB No.: 202159	LGA: STRATHFIELD
PLAN No.: 202159-2	DATUM: AHD
DATE: 20/11/2020	SCALE: 1:100@A0
DRAWN: CC	CONT. INTERVAL: 0.25m
CHK: MB	SHEET 12 OF 12