

BASIX[®] commitments

Assessor Mr. Daniel Warda
 Date 11 / 11 / 2021
 BASIX Certificate No. 1258565S
 NATHERS Certificate No. 0006779730

project details

Site Address Lot 36, 13 The Causeway, Strathfield South NSW 2138
 Municipality Strathfield Municipal
 Reference 29914372

thermal comfort

Floors 300mm Waffle Pod Slab as per job number 29914372
 Cantilevered Floors N/A
 External Walls R1.5 Bulk Insulation to all external walls | Medium
 Internal Walls Same value as external walls applied to Garage internal walls only
 Ceilings R3.5 Bulk Insulation to all trussed ceilings over living areas
 Roof Colorbond | Medium
 Roof Insulation 80mm Anti-Con Blanket

Stegbar Windows (Aluminium Framed - Standard 3mm Clear) U - Value: 6.5 SHGC: 0.65
 • To all awning & fixed windows excluding any mentioned below

Stegbar Sliding Door (Aluminium Framed - Standard 5mm Clear) U - Value: 6.3 SHGC: 0.72
 • To all sliding doors excluding any mentioned below

Stegbar Windows (Aluminium Framed - Standard 3mm Clear) U - Value: 6.3 SHGC: 0.73
 • To all sliding windows excluding any mentioned below

Note: U-Value may be lower but not higher than the nominated values
 Note: SHGC may have a tolerance of +/- 10% of the nominated values in NSW only

Skylights N/A

water

Landscape Area 273m²
 W.C.'s 4 Star
 Kitchen Taps 4 Star
 Shower Heads 3 Star (>7.5 but <=9L/min)
 Basin Taps 4 Star
 Alternative Water 3068L Rain Water Tank
 Min. Roof Area To Tank 60m²
 All Water Uses Garden, W/C & Laundry

energy

Hot Water System Gas Instantaneous | 6 Stars
 Cooling System 3-Phase Ducted Air-Con | EER 3.0-3.5
 Heating System 3-Phase Ducted Air-Con | EER 3.0-3.5
 Ventilation As Per Basix Assessment
 PV System N/A
 Cooking Gas Cooktop & Electric Oven
 Drying Outdoor Clothesline
 Lighting As Per BASIX Certificate

swimming pool

Pool / Spa N/A
 Shading / Timer N/A
 Cover N/A



0488 203 806

giuseppe@energiasessments.com.au

ABN 77 614 736 284

0006779730 11 Nov 2021
 Assessor Daniel Warda
 Accreditation No. 101182
 Address The Causeway, Strathfield South, NSW, 2136
 hstar.com.au

AREAS	
SITE:	580.60 m ²
GROUND FLOOR:	165.24 m ²
FIRST FLOOR:	196.75 m ²
GARAGE:	38.45 m ²
PORCH:	4.34 m ²
BALCONY:	N/A m ²
ALFRESCO:	52.29 m ²
	m ²
TOTAL:	457.37 m ²

SHEET	DESCRIPTION
2.4	SHADOW DIAGRAMS
2.3	NEIGHBOUR NOTIFICATION PLAN
2.2	SITE ANALYSIS
2.1	CONSTRUCTION MANAGEMENT
11	WET AREA DETAILS
10	WET AREA DETAILS
9	WET AREA DETAILS
8	ELECTRICAL LAYOUT
7	SECTION
6	ELEVATIONS
5	ELEVATIONS
4	FIRST FLOOR PLAN
3	GROUND FLOOR PLAN
2	SITE PLAN
1	COVER SHEET

QUOTE	DATE	QUOTE NUMBER	REV	REV	DATE	AMENDMENTS	BY
KITCHEN			-				
ZURCORP ELECTRICAL			-				
TILES			-				
CARPET			-				
ZURCORP SECURITY			-				
EHI			-	H	11.02.22	COUNCIL AMENDMENTS - ADDITION DIMENSIONS & LEVELS	M.H.
AIR CONDITIONING			-	G	25.01.22	EXTERNAL COLOURS	PG.
STAIRS			-	F	09.12.21	HYDRAULICS & LANDSCAPE CO-ORDINATED	M.H.
LANDSCAPE				E	24.11.21	DA DRAWINGS	PG.
HYDRAULICS				D	02.11.21	PCV1	PG.
ENGINEER				C	16.07.21	CONTRACT DRAWINGS	PG.
PEG OUT				B	08.12.20	CONTRACT DRAWINGS	PG.
				A	17.11.20	TENDER SITING	PJ

CLIENT'S SIGNATURE: _____

DATE: _____

REV

DATE

AMENDMENTS

BY

ClarendonHomes
 BL No. 2298C
 ABN 18 003 892 706
 Clarendon Homes (NSW) P/L
 21 Solent Circuit, Baulkham Hills NSW 2153
 T: (02) 8851 5300

© ALL RIGHTS RESERVED
 This plan is the property of
 CLARENDON HOMES (NSW) P/L
 Any copying or altering
 of the drawing shall not be
 undertaken without written
 permission from
 CLARENDON HOMES (NSW) P/L
 # ALL DIMENSIONS TO STRUCTURAL
 ELEMENTS. DIMENSIONS TO BE READ
 IN PREFERENCE TO SCALING.

PRODUCT:
BOSTON 42
 Malibu
 R/H Garage
 Sapphire Specification
 Master Issued: 14.05.19 Revision: C

CLIENT:
 Ms. TAN
 SITE ADDRESS:
 Lot 36 No.13
 The Causeway
 STRATHFIELD SOUTH 2136

DA DRAWINGS			
DRAWN:	DATE:	Rev:	
PG.	08.12.20	H	
RATIO @ A3:	CHECKED:		
N/A	J.S		
SHEET:	JOB No:		
1	29914372		NSW

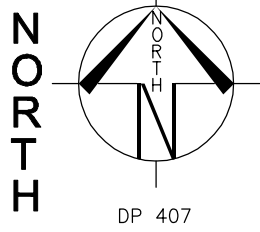

SITE COVERAGE STORMWATER CALCULATION	
ROOF FOOTPRINT:	260.8m ²
DRIVEWAY/ PAVED AREAS:	43.5m ²
TOTAL:	304.3m ²
	52.4 %
MAX SITE COVERAGE FOR OSD:	65%

LOT 36
D.P: 407 SEC: 1
L.G.A: STRATHFIELD

**SITING HAS BEEN COMPLETED
 IN ACCORDANCE WITH
 STRATHFIELD DCP 2005**

SITE AREA	580.6 m ²
ROOF AREA	260.8 m ²

FLOOR SPACE RATIO	
GROUND FLOOR:	151.3 m ²
FIRST FLOOR:	179.5 m ²
TOTAL LIVING AREA: (EXCLUDES EXT. WALLS, GARAGE, STAIR VOID, ETC.) (EXCLUDES PORCH, ALFRESCO, ETC.)	330.8 m ²
FLOOR SPACE RATIO:	56.9 %
MAX. ALLOWABLE BY COUNCIL:	62.5 %

LANDSCAPED AREA	
TOTAL LANDSCAPE AREA: (EXCLUDES HARD SURFACES)	272.9 m ² 47.0 %
MIN. REQUIRED BY COUNCIL:	38.5 %

HEIGHT RESTRICTION	
MAXIMUM RIDGE HEIGHT	9.5 m
(F.F.L. MUST BE ACCURATE. CHANGES IN LEVELS MAY NOT COMPLY WITH REQUIREMENTS)	

WIND CLASSIFICATION: "N2"

SLAB CLASSIFICATION: "H1"

NOTE:
 ALL GROUND LINES ARE APPROXIMATE.
 EXTENT OF FILL & BATTER WILL BE
 DETERMINED ON SITE. SEDIMENT BARRIERS
 ARE TO BE CUSTOMISED SITE SPECIFIC

NOTE:
 OWNER TO DEMOLISH & REMOVE FROM
 SITE EXISTING HOUSE, INCLUDING
 FOOTINGS & SERVICES ABOVE & BELOW
 GROUND, PATHS, DRIVE, TREES &
 FENCES ETC. PRIOR TO COMMENCEMENT
 OF CONSTRUCTION.

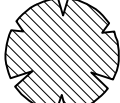
 DENOTES TREES TO BE
 REMOVED BY OWNER
 PRIOR TO CONSTRUCTION

SEC 1
LOT 8

SEC 1
LOT 7

SEC 1
LOT 6

APPROX. LOCATION OF SEWER SEE SEWER DIAGRAM

LOT 35
SEC 1

LOT 37
SEC 1

PROVIDE CONCRETE LANDING
AND STEPS BY CLARENDON

TWO STOREY
BRICK, REND.
TILE ROOF
No.15

LOCATION OF 3088L
SLIMLINE ABOVE GROUND
RAINWATER TANK
(2800Lx750Wx1560H)

LOCATION OF AIR
CONDITIONING UNIT

LOCATION
OF METER
BOX

DROP EDGE BEAM
0.650H F.F.L TO N.G.L

LOT 36
580.6m²
SEC 1

**PROPOSED
RESIDENCE**
 FFL R.L. 18.000
 FGL R.L. 17.615

**GARAGE
STEPDOWN**
 343mm
 FFL R.L. 17.657
 FGL R.L. 17.272

PROVIDE CONCRETE LANDING
AND STEPS BY CLARENDON

PROPOSED DRIVEWAY
AND GRATED DRAIN,
BY OWNER AFTER
HANDOVER

EXISTING CROSSOVER
TO REMAIN

APPROX. LOCATION
OF SEWER

THE CAUSEWAY

**LEVELS TO BE STRICTLY ADHERED
TO AS SHOWN ON SITE PLAN
NO + OR - 100mm
TOLERANCE TO LEVELS**

SITE PLAN

SCALE 1:200

GENERAL NOTES

- A) THIS SURVEY IS SPECIFICALLY FOR CONTOUR PURPOSES ONLY. THE BOUNDARIES OF THE SUBJECT PROPERTY HAVE NOT BEEN INVESTIGATED
- B) AREAS AND DIMENSIONS ARE SUBJECT TO SURVEY
- C) SERVICES SHOWN HAVE BEEN DERIVED FROM VISUAL EVIDENCE APPARENT AT THE TIME OF SURVEY. THE RELEVANT SERVICE AUTHORITY SHALL BE CONTACTED TO VERIFY THE EXISTENCE AND POSITION OF ALL SERVICES PRIOR TO THE COMMENCEMENT OF ANY CONSTRUCTION OR EXCAVATION
- D) CONTOURS ARE INDICATIVE OF SURFACE TOPOGRAPHY ONLY. SURVEYED SPOT LEVELS ARE THE ONLY VALUES TO BE RELIED ON FOR REDUCED LEVELS ON PARTICULAR FEATURES.

CLIENT'S SIGNATURE: _____ DATE: _____

ClarendonHomes

BL No. 2298C
 ABN 18 003 892 706
 Clarendon Homes (NSW) P/L
 21 Solent Circuit, Baulkham Hills NSW 2153
 T: (02) 8851 5300

© ALL RIGHTS RESERVED
 This plan is the property of
 CLARENDON HOMES (NSW) P/L
 Any copying or altering
 of the drawing shall not be
 undertaken without written
 permission from
 CLARENDON HOMES (NSW) P/L
 # ALL DIMENSIONS TO STRUCTURAL
 ELEMENTS. DIMENSIONS TO BE READ
 IN PREFERENCE TO SCALING.

PRODUCT:
BOSTON 42
 Malibu
 R/H Garage
 Sapphire Specification

CLIENT:
 Ms. TAN
 SITE ADDRESS:
 Lot 36 No.13
 The Causeway
 STRATHFIELD SOUTH 2136

DA DRAWINGS

DRAWN: PG.	DATE: 08.12.20	Rev:
RATIO @ A3: 1:200	CHECKED: J.S	H
SHEET: 2	JOB No: 29914372	NSW

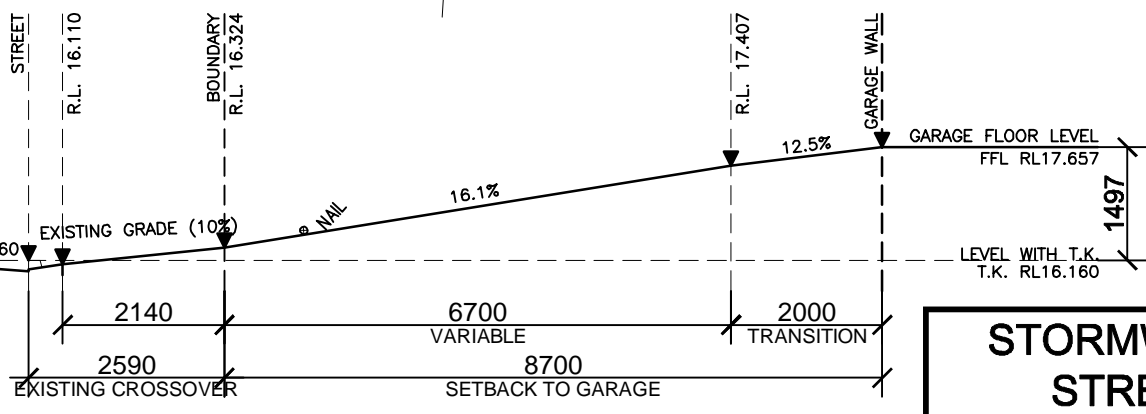

DRIVEWAY GRADIENT PROFILE

SCALE-1:100

**STORMWATER TO
STREET VIA
RAINWATER TANK**

REFER TO HYDRAULIC DETAILS

● AIR CONDITIONING DUCT

Ⓢ SMOKE ALARM

⊗ EXHAUST FAN

DP ○ DOWN PIPE LOCATION

⊕ LIFT OFF HINGES

SP ○ STEEL POST

TSP ○ TELESCOPIC STEEL POST

ARTICULATION JOINTS TO ENGINEERS DETAILS

NOTE:
PROVIDE GREY EPOXY FLOOR FINISH TO GARAGE ONLY

NOTE:
SHOWER NOOK/RECESS REFER TO **CDN 54.260** & SHEET 10 FOR DETAILS

NOTE:
INTERNAL DOOR LEAF HEIGHTS TO GROUND FLOOR TO BE 2340mm(H)

NOTE:
PROVIDE (x4) 450mm DEEP MELAMINE SHELIVING TO W.I.P

NOTE:
(UNLESS NOTED OTHERWISE)
300 DEEP BULKHEADS & SQ. SETS. 150 DROPPED CEILINGS

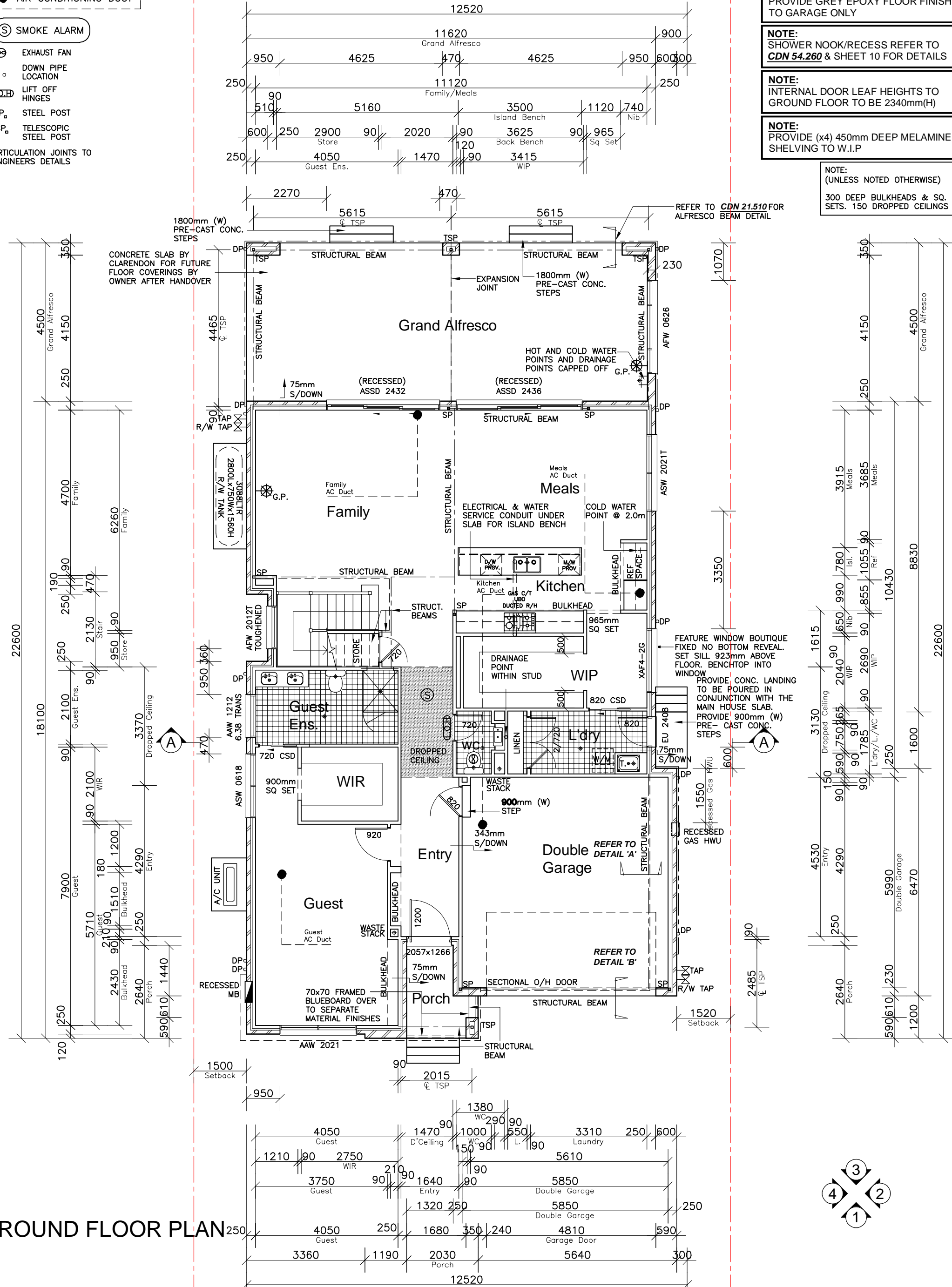

GROUND FLOOR PLAN

CLIENT'S SIGNATURE: _____

DATE: _____

ClarendonHomes
BL No. 2298C
ABN 18 003 892 706
Clarendon Homes (NSW) P/L
21 Solent Circuit, Baulkham Hills NSW 2153
T: (02) 8851 5300

© ALL RIGHTS RESERVED
This plan is the property of CLARENDON HOMES (NSW) P/L
Any copying or altering of the drawing shall not be undertaken without written permission from CLARENDON HOMES (NSW) P/L
ALL DIMENSIONS TO STRUCTURAL ELEMENTS. DIMENSIONS TO BE READ IN PREFERENCE TO SCALING.

PRODUCT:
BOSTON 42
Malibu
R/H Garage
Sapphire Specification

CLIENT:
Ms. TAN
SITE ADDRESS:
Lot 36 No.13
The Causeway
STRATHFIELD SOUTH 2136

DA DRAWINGS		
DRAWN: PG.	DATE: 08.12.20	Rev: H
RATIO @ A3: 1:100	CHECKED: J.S	
SHEET: 3	JOB No: 29914372	NSW

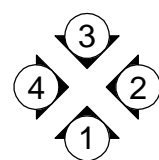

● AIR CONDITIONING DUCT

Ⓢ SMOKE ALARM

DP ○ DOWN PIPE LOCATION

ⓁⓁ LIFT OFF HINGES

SP ○ STEEL POST

TSP ○ TELESCOPIC STEEL POST

ARTICULATION JOINTS TO ENGINEERS DETAILS

⊗ EXHAUST FAN

NOTE:
(UNLESS NOTED OTHERWISE)
300 DEEP BULKHEADS & SQ. SETS. 150 DROPPED CEILINGS

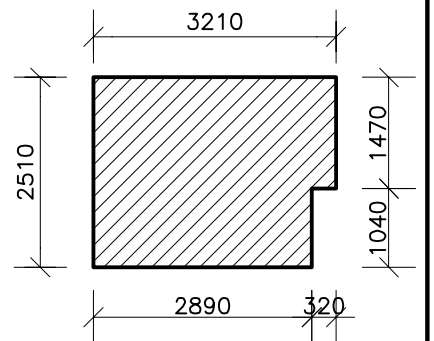

STAIR CUTOUT
SCALE 1:100

NOTE:
ALL FIRST FLOOR BEDROOM & LIVING WINDOWS TO BE FITTED WITH A RESTRICTING DEVICE COMPLIANT WITH PART 3.9.2.5 OF THE B.C.A - PROTECTION OF OPENABLE WINDOWS

NOTE:
SHOWER NOOK/RECESS REFER TO **CDN 54.260** & SHEET 11 FOR DETAILS

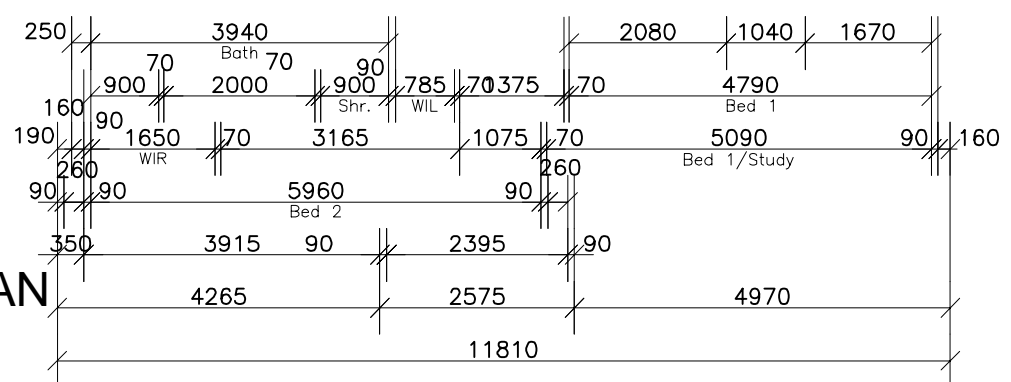
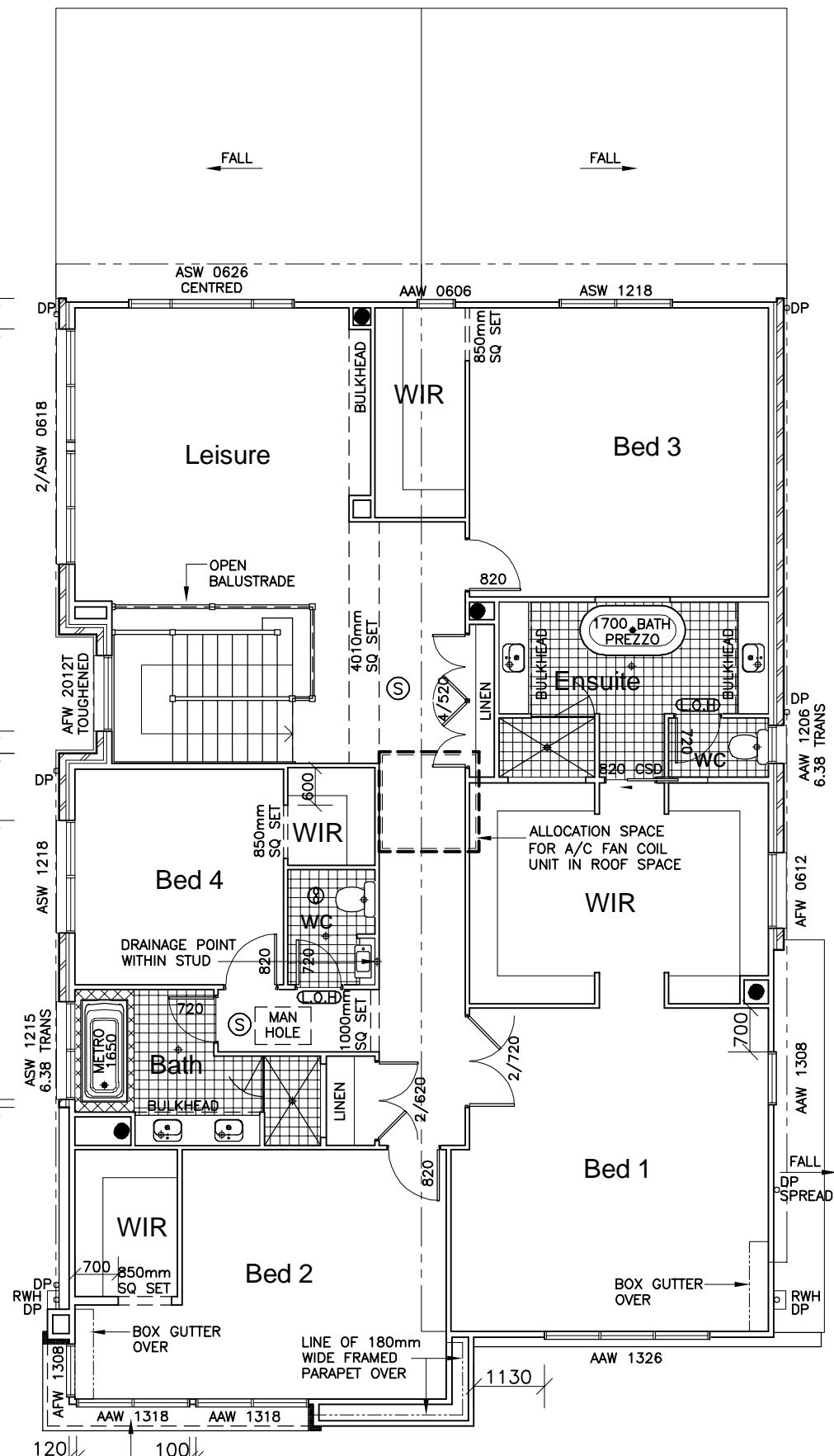
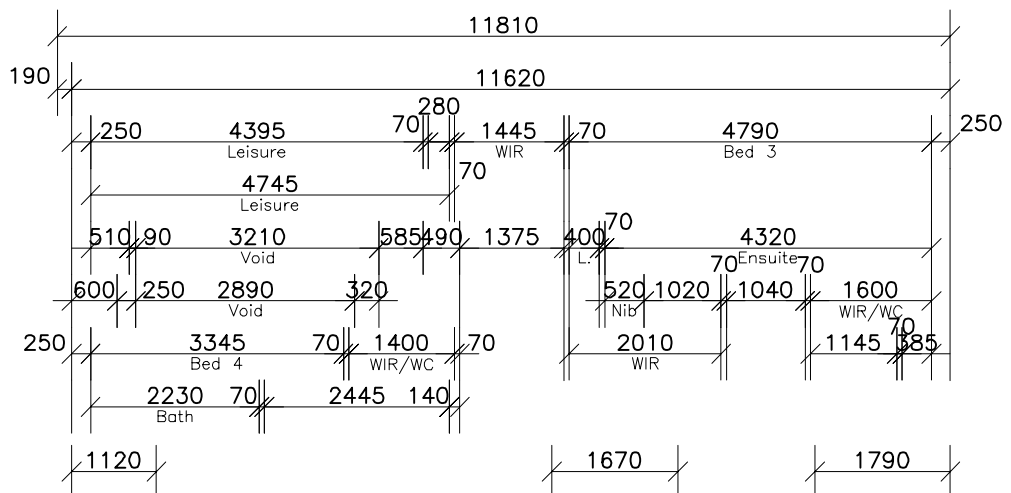
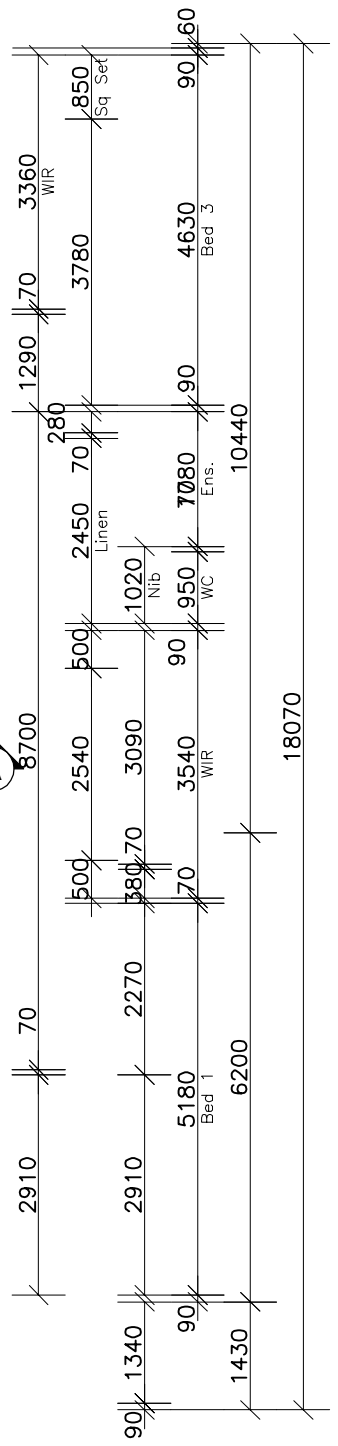
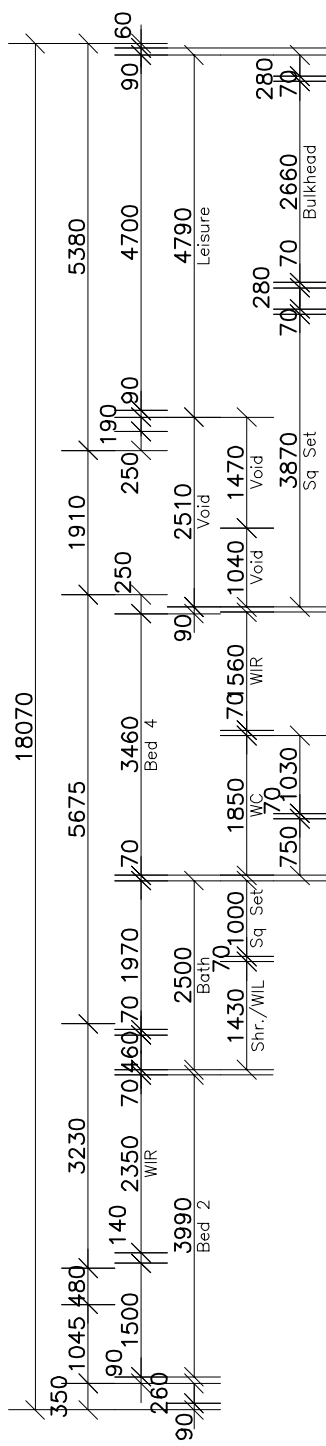

FIRST FLOOR PLAN

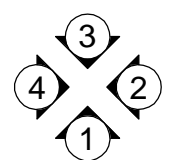

CLIENT'S SIGNATURE: _____

DATE: _____

ClarendonHomes
BL No. 2298C
ABN 18 003 892 706
Clarendon Homes (NSW) P/L
21 Solent Circuit, Baulkham Hills NSW 2153
T: (02) 8851 5300

© ALL RIGHTS RESERVED
This plan is the property of CLARENDON HOMES (NSW) P/L
Any copying or altering of the drawing shall not be undertaken without written permission from CLARENDON HOMES (NSW) P/L
ALL DIMENSIONS TO STRUCTURAL ELEMENTS. DIMENSIONS TO BE READ IN PREFERENCE TO SCALING.

PRODUCT:
BOSTON 42
Malibu
R/H Garage
Sapphire Specification

CLIENT:
Ms. TAN
SITE ADDRESS:
Lot 36 No.13
The Causeway
STRATHFIELD SOUTH 2136

DA DRAWINGS		
DRAWN: PG.	DATE: 08.12.20	Rev: H
RATIO @ A3: 1:100	CHECKED: J.S	
SHEET: 4	JOB No: 29914372	NSW

NOTE:
HEIGHT OF DROP EDGE BEAM MAY VARY DUE TO SITE CONDITIONS UPON COMPLETION OF SITE WORKS

NOTE:
NUMBER OF STEPS REQUIRED MAY VARY DEPENDING ON SITE CONDITIONS

 DENOTES WINDOWS WITH 6.38MM TRANSLUCENT LAMINATED GLAZING

NOTES:
FOR DROP-OFF'S REFER TO FRAMING DETAILS
CDN 21.010-21.080

NOTE:
FOR ROOF PITCHES 20° OR LOWER - ROOF TILE SELECTION WILL BE IMPACTED.

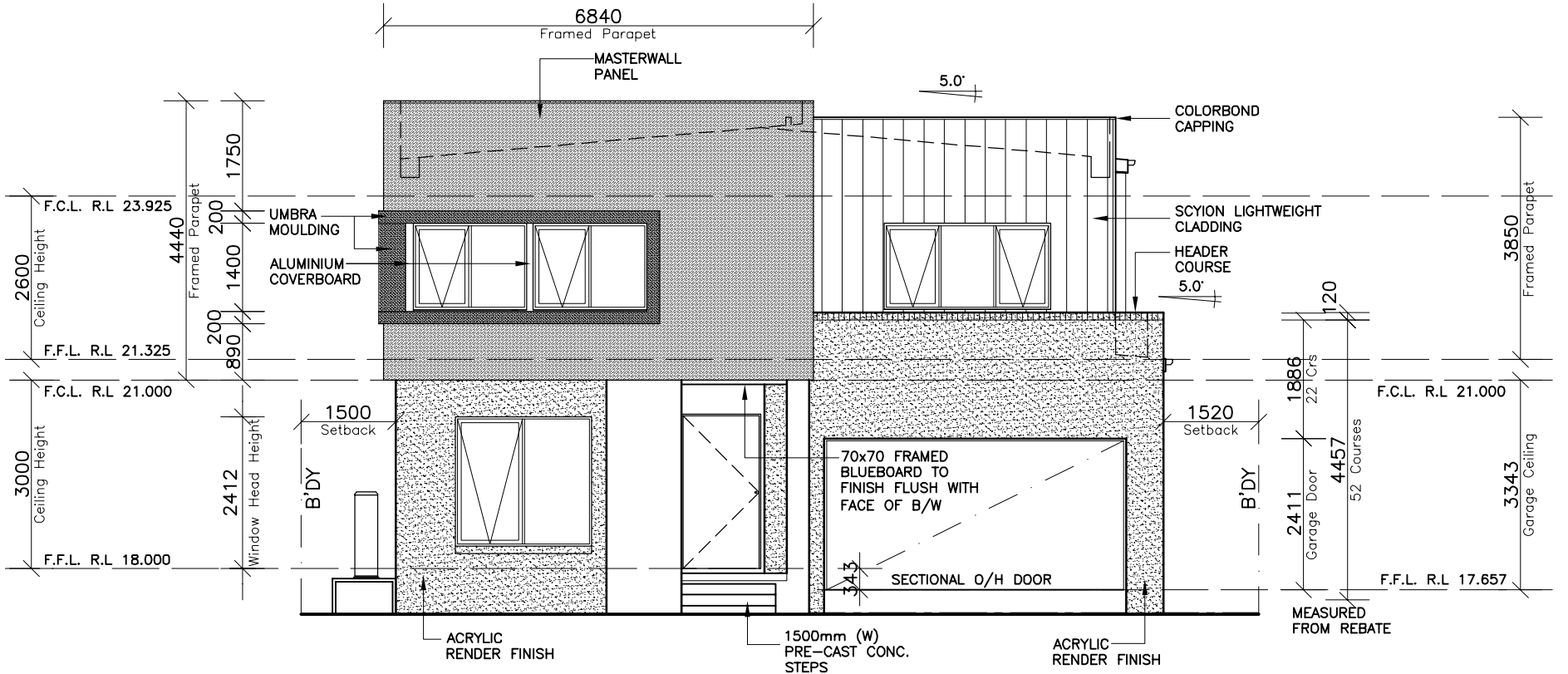

**ELEVATION 1
-SOUTH-**

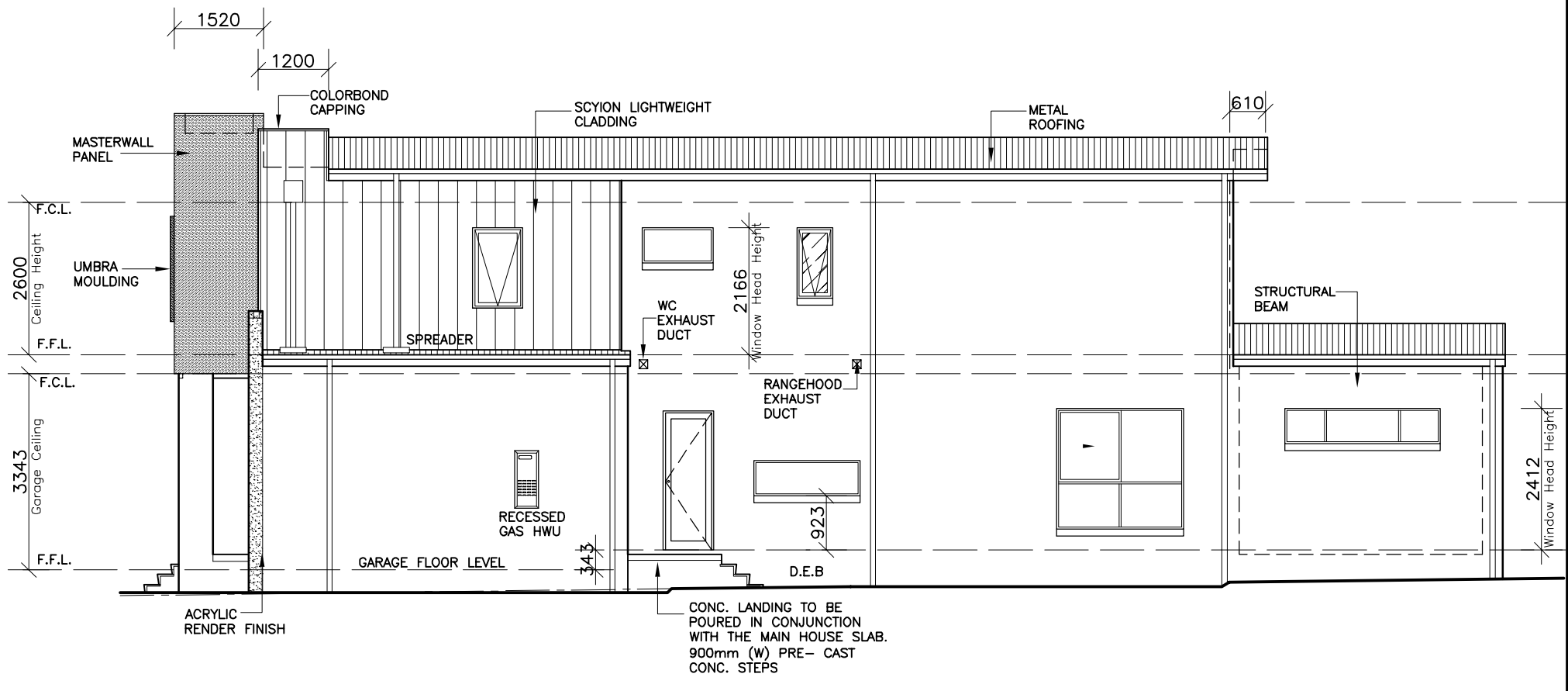

**ELEVATION 2
-EAST-**

CLIENT'S SIGNATURE: _____ DATE: _____

ClarendonHomes
BL No. 2298C
ABN 18 003 892 706
Clarendon Homes (NSW) P/L
21 Solent Circuit, Baulkham Hills NSW 2153
T: (02) 8851 5300

© ALL RIGHTS RESERVED
This plan is the property of CLARENDON HOMES (NSW) P/L
Any copying or altering of the drawing shall not be undertaken without written permission from CLARENDON HOMES (NSW) P/L
ALL DIMENSIONS TO STRUCTURAL ELEMENTS. DIMENSIONS TO BE READ IN PREFERENCE TO SCALING.

PRODUCT:
BOSTON 42
Malibu
R/H Garage
Sapphire Specification

CLIENT:
Ms. TAN
SITE ADDRESS:
Lot 36 No.13
The Causeway
STRATHFIELD SOUTH 2136

DA DRAWINGS			
DRAWN: PG.	DATE: 08.12.20	Rev:	H
RATIO @ A3: 1:100	CHECKED: J.S		
SHEET: 5	JOB No: 29914372		NSW

NOTE:
HEIGHT OF DROP EDGE BEAM MAY VARY DUE TO SITE CONDITIONS UPON COMPLETION OF SITE WORKS

NOTE:
NUMBER OF STEPS REQUIRED MAY VARY DEPENDING ON SITE CONDITIONS

 DENOTES WINDOWS WITH 6.38MM TRANSLUCENT LAMINATED GLAZING

NOTES:
FOR DROP-OFF'S REFER TO FRAMING DETAILS
CDN 21.010-21.080

NOTE:
FOR ROOF PITCHES 20° OR LOWER - ROOF TILE SELECTION WILL BE IMPACTED.

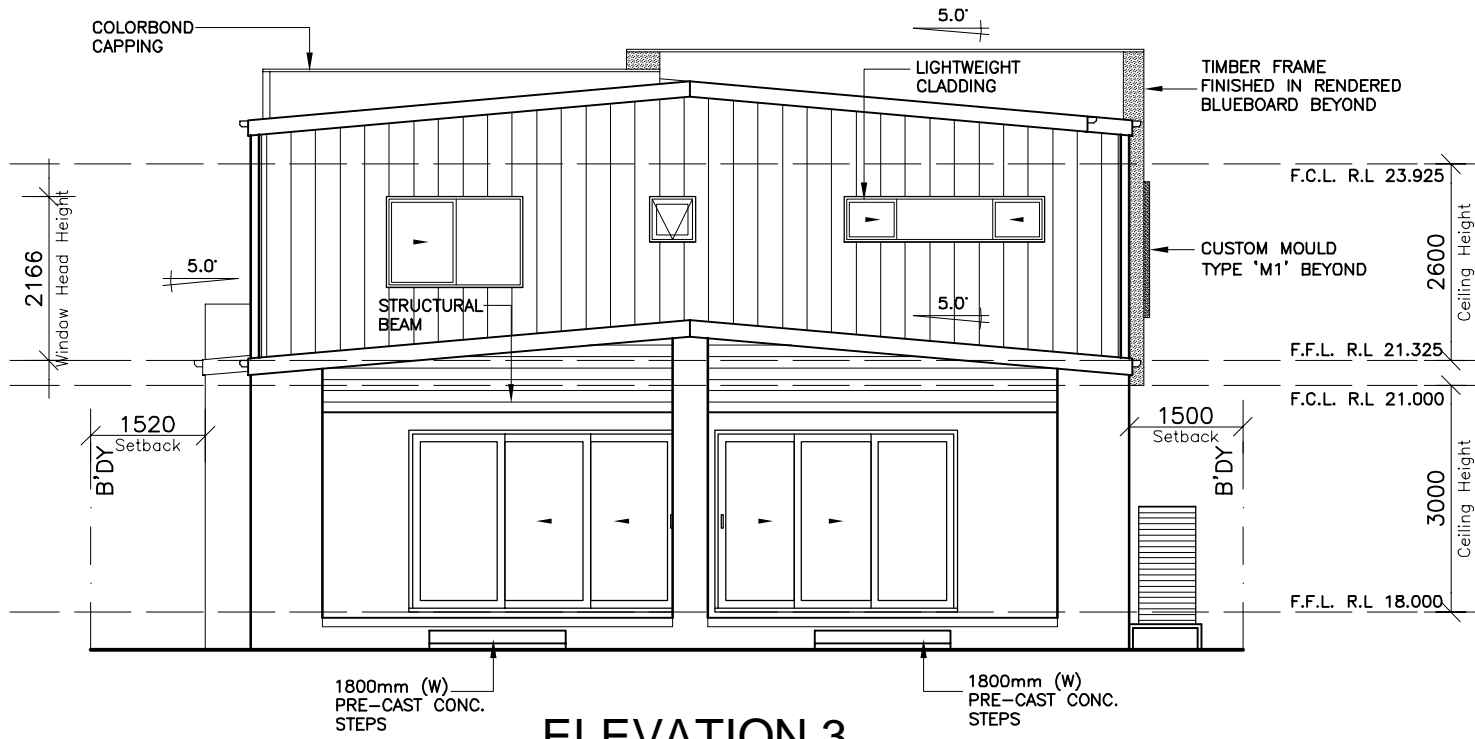

**ELEVATION 3
-NORTH-**

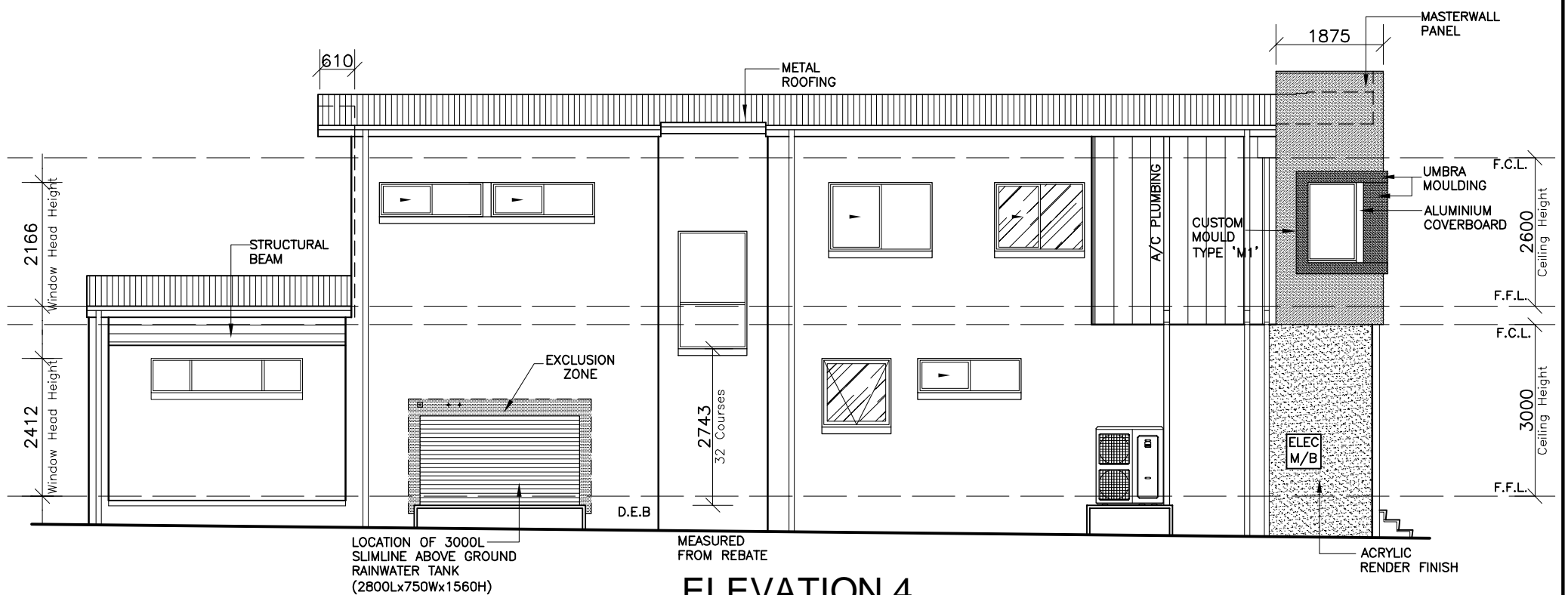

**ELEVATION 4
-WEST-**

CLIENT'S SIGNATURE: _____ DATE: _____

ClarendonHomes
BL No. 2298C
ABN 18 003 892 706
Clarendon Homes (NSW) P/L
21 Solent Circuit, Baulkham Hills NSW 2153
T: (02) 8851 5300

© ALL RIGHTS RESERVED
This plan is the property of CLARENDON HOMES (NSW) P/L
Any copying or altering of the drawing shall not be undertaken without written permission from CLARENDON HOMES (NSW) P/L
ALL DIMENSIONS TO STRUCTURAL ELEMENTS. DIMENSIONS TO BE READ IN PREFERENCE TO SCALING.

PRODUCT:
BOSTON 42
Malibu
R/H Garage
Sapphire Specification

CLIENT:
Ms. TAN
SITE ADDRESS:
Lot 36 No.13
The Causeway
STRATHFIELD SOUTH 2136

DA DRAWINGS			
DRAWN: PG.	DATE: 08.12.20	Rev:	H
RATIO @ A3: 1:100	CHECKED: J.S		
SHEET: 6	JOB No: 29914372		NSW

NOTE:
INTERNAL DOOR LEAF HEIGHTS TO
GROUND FLOOR TO BE 2340mm(H)

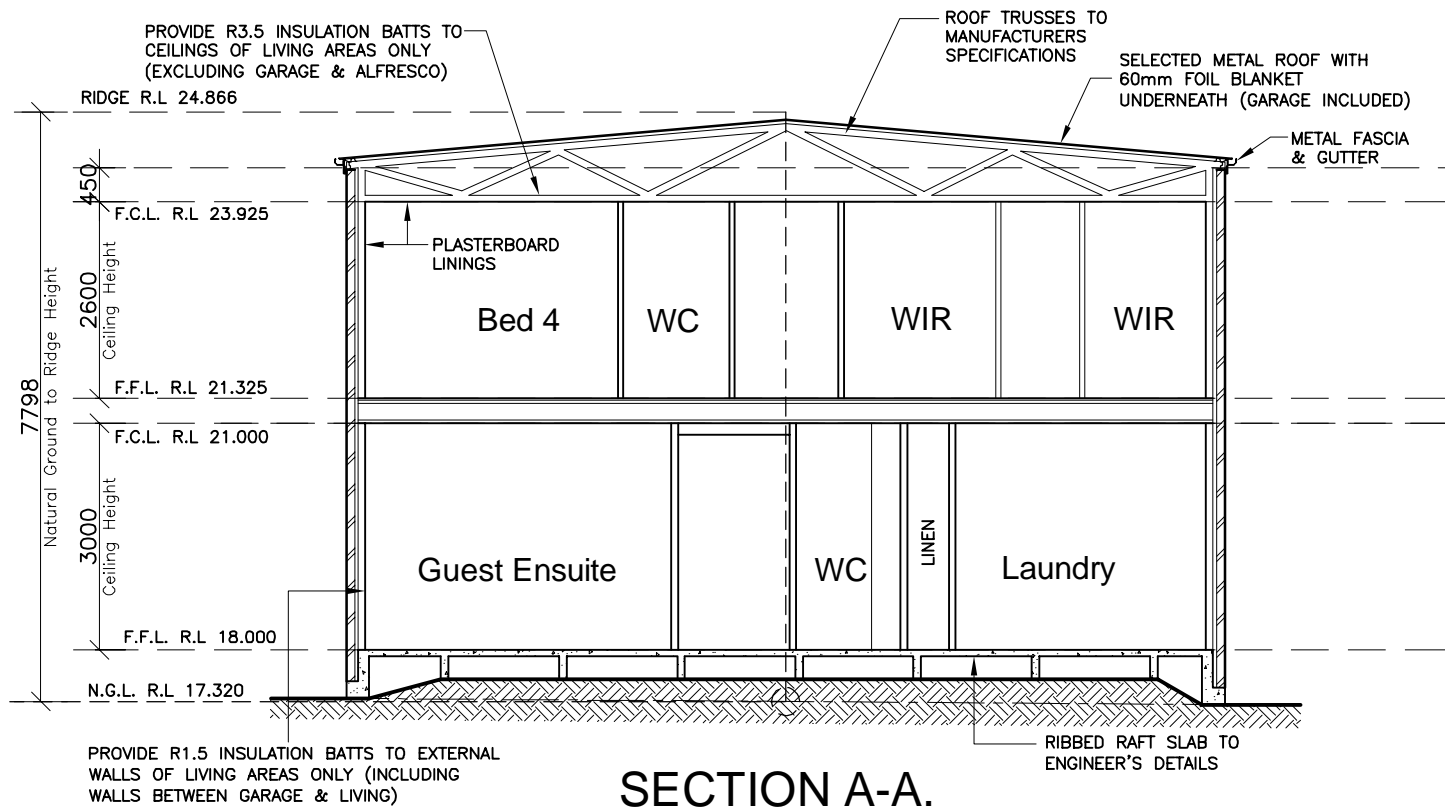

SECTION A-A.

NOTE: THIS SECTION OF BALUSTRADE IS TO FINISH TO UNDERSIDE OF CEILING AND TO BE ADJUSTED AS REQUIRED FOR NON-STANDARD CEILING HEIGHTS.

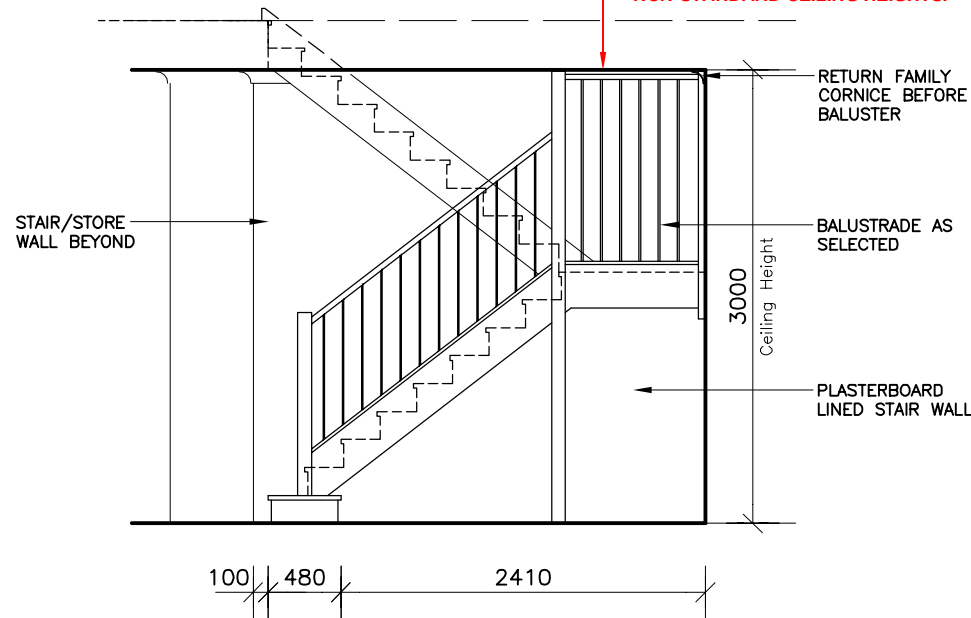

STAIR ELEVATION

VIEWED FROM FAMILY
SCALE 1:50

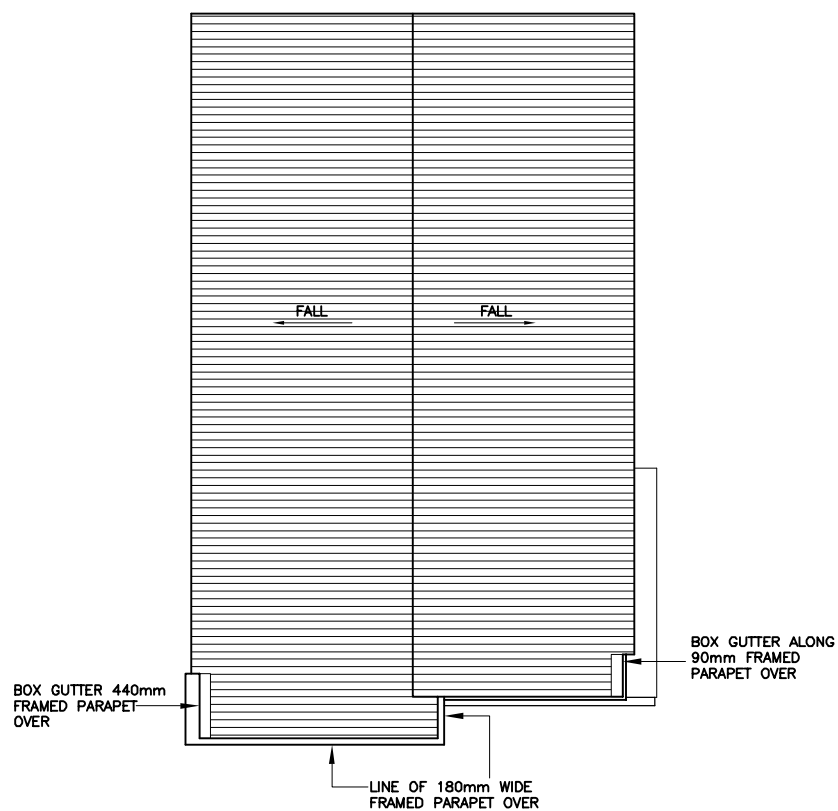

ROOF PLAN

SCALE: 1:200

CLIENT'S SIGNATURE: _____ DATE: _____

ClarendonHomes
BL No. 2298C
ABN 18 003 892 706
Clarendon Homes (NSW) P/L
21 Solent Circuit, Baulkham Hills NSW 2153
T: (02) 8851 5300

© ALL RIGHTS RESERVED
This plan is the property of
CLARENDON HOMES (NSW) P/L
Any copying or altering
of the drawing shall not be
undertaken without written
permission from
CLARENDON HOMES (NSW) P/L
ALL DIMENSIONS TO STRUCTURAL
ELEMENTS. DIMENSIONS TO BE READ
IN PREFERENCE TO SCALING.

PRODUCT:
BOSTON 42
Malibu
R/H Garage
Sapphire Specification

CLIENT:
Ms. TAN
SITE ADDRESS:
Lot 36 No.13
The Causeway
STRATHFIELD SOUTH 2136

DA DRAWINGS

DRAWN: PG.	DATE: 08.12.20	Rev:
RATIO @ A3: 1:100	CHECKED: J.S	H
SHEET: 7	JOB No: 29914372	NSW

NORTH

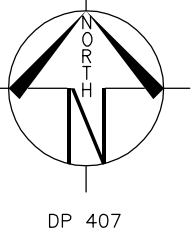

LOT 36
D.P: 407 SEC: 1
L.G.A: STRATHFIELD

SITING HAS BEEN COMPLETED
IN ACCORDANCE WITH
STRATHFIELD DCP 2005

SEC 1
LOT 8

SEC 1
LOT 7

SEC 1
LOT 6

APPROX. LOCATION OF SEWER SEE SEWER DIAGRAM

LOT 35
SEC 1

LOT 37
SEC 1

APPROXIMATE LOCATION OF SEDIMENT FENCE

TWO STOREY RENDERED, CLAD TILE ROOF No.11

LOT 36
580.6m²
SEC 1

PROPOSED RESIDENCE
FFL R.L. 18.000
FGL R.L. 17.615

GARAGE
STEPDOWN
343mm
FFL R.L. 17.657
FGL R.L. 17.272

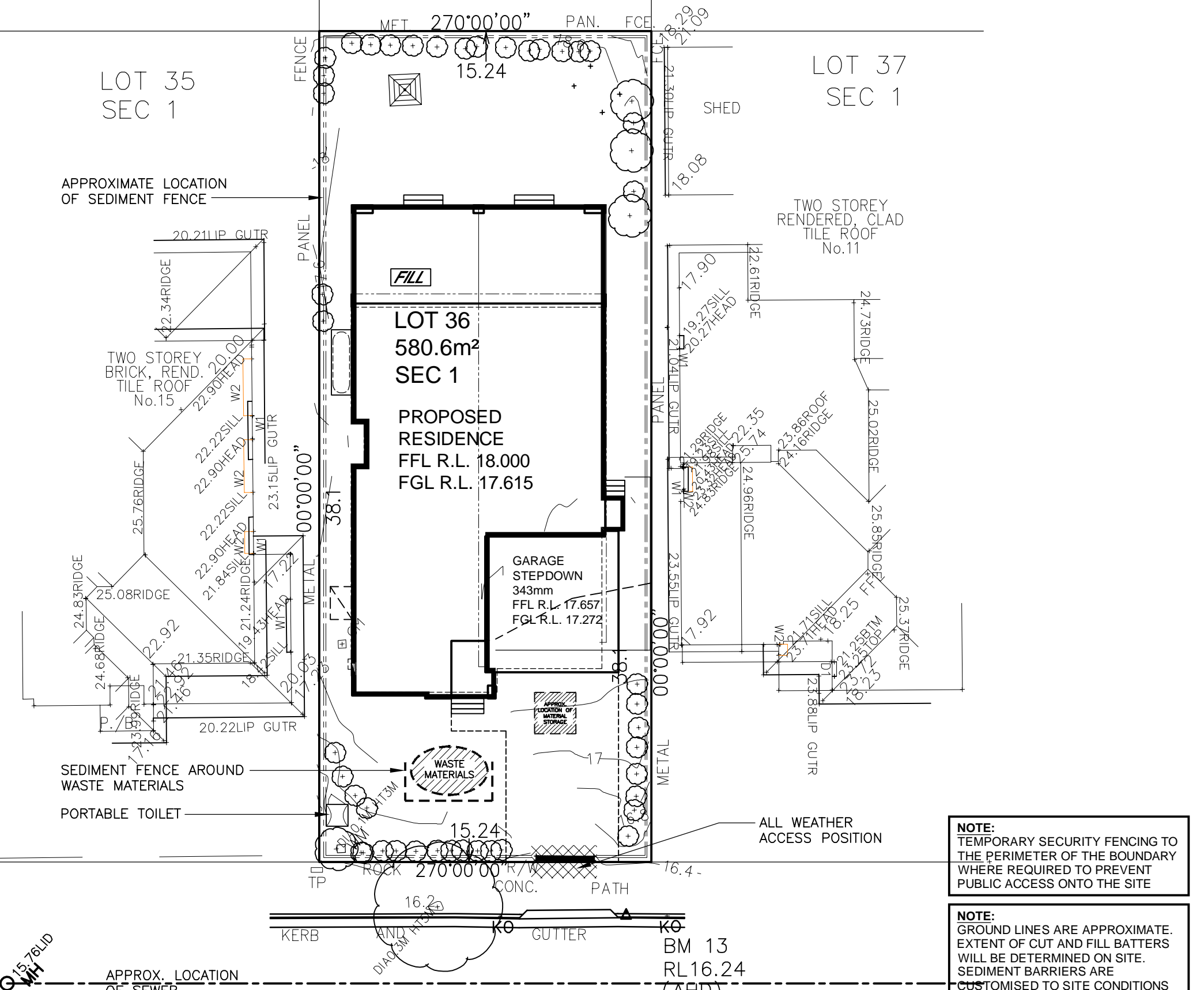

NOTE:
TEMPORARY SECURITY FENCING TO THE PERIMETER OF THE BOUNDARY WHERE REQUIRED TO PREVENT PUBLIC ACCESS ONTO THE SITE

NOTE:
GROUND LINES ARE APPROXIMATE. EXTENT OF CUT AND FILL BATTERS WILL BE DETERMINED ON SITE. SEDIMENT BARRIERS ARE CUSTOMISED TO SITE CONDITIONS

SEDIMENT CONTROL NOTES

- ALL EROSION AND SEDIMENTATION CONTROL MEASURES, INCLUDING REVEGETATION AND STORAGE OF SOIL AND TOPSOIL, SHALL BE IMPLEMENTED TO THE STANDARDS OF THE SOIL CONSERVATION OF NSW AND INSPECTED DAILY BY THE SITE MANAGER.
- ALL DRAINAGE WORKS SHALL BE CONSTRUCTED AND STABILIZED AS EARLY AS POSSIBLE DURING DEVELOPMENT.
- SEDIMENT TRAPS SHALL BE CONSTRUCTED AROUND ALL INLET PITS, CONSISTING OF 300mm WIDE x 300mm DEEP TRENCH.
- ALL SEDIMENT BAGS AND TRAPS SHALL BE CLEARED WHEN THE STRUCTURES ARE A MAXIMUM OF 60% FULL OF SOIL MATERIALS, INCLUDING THE MAINTENANCE PERIOD.
- ALL DISTURBED AREAS SHALL BE REVEGETATED AS SOON AS THE RELEVANT WORKS ARE COMPLETED.
- SOIL AND TOPSOIL STOCKPILES SHALL BE LOCATED AWAY FROM DRAINAGE LINES AND AREA WHERE WATER MAY CONCENTRATE. ALL ROADS AND FOOTPATHS TO BE SWEEP DAILY.
- FILTER SHALL BE CONSTRUCTED BY STRETCHING A FILTER FABRIC (PROPEX OR APPROVED EQUIVALENT) BETWEEN POST AT 3.0m CENTRES. FABRIC SHALL BE BURIED 150mm ALONG ITS LOWER EDGE.
- DUST PREVENTION MEASURES TO BE MAINTAINED AT ALL TIMES.

SEDIMENT FENCE
NOT TO SCALE

CONSTRUCTION MANAGEMENT PLAN EROSION AND SEDIMENT CONTROL PLAN

CLIENT'S SIGNATURE: _____ DATE: _____

ClarendonHomes
BL No. 2298C
ABN 18 003 892 706
Clarendon Homes (NSW) P/L
21 Solent Circuit, Baulkham Hills NSW 2153
T: (02) 8851 5300

© ALL RIGHTS RESERVED
This plan is the property of CLARENDON HOMES (NSW) P/L. Any copying or altering of the drawing shall not be undertaken without written permission from CLARENDON HOMES (NSW) P/L.
ALL DIMENSIONS TO STRUCTURAL ELEMENTS. DIMENSIONS TO BE READ IN PREFERENCE TO SCALING.

PRODUCT:
BOSTON 42
Malibu
R/H Garage
Sapphire Specification

CLIENT:
Ms. TAN
SITE ADDRESS:
Lot 36 No.13
The Causeway
STRATHFIELD SOUTH 2136

DA DRAWINGS			
DRAWN: PG.	DATE: 08.12.20	Rev: H	
RATIO @ A3: 1:200	CHECKED: J.S		
SHEET: 2.1	JOB No: 29914372	NSW	

NORTH

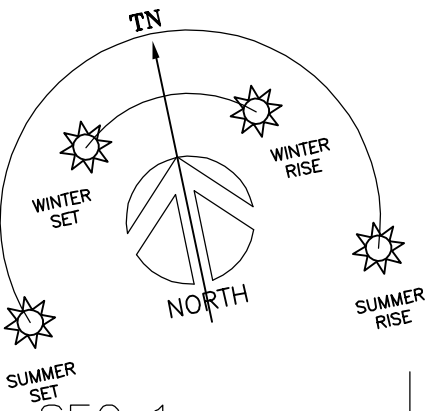

LOT 36
D.P: 407 SEC: 1
L.G.A: STRATHFIELD

SITING HAS BEEN COMPLETED
IN ACCORDANCE WITH
STRATHFIELD DCP 2005

SEC 1
LOT 8

SEC 1
LOT 7

SEC 1
LOT 6

APPROX. LOCATION
OF SEWER

SEE

SEWER

DIAGRAM

LOT 35
SEC 1

MET 270'00"00" PAN. FCE.

15.24

LOT 37
SEC 1

SHED

TWO STOREY
RENDERED, CLAD
TILE ROOF
No.11

TWO STOREY
BRICK, REND.
TILE ROOF
No.15

LOT 36
580.6m²
SEC 1

PROPOSED
RESIDENCE
FFL R.L. 18.000
FGL R.L. 17.615

2

GARAGE
STEPDOWN
343mm
FFL R.L. 17.657
FGL R.L. 17.272

1 / 2

NUMBER OF STOREYS



PRINCIPAL PRIVATE
OPEN SPACE



MAIN VIEWS



NOISE IMPACT

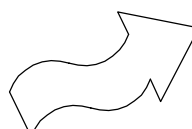

PREVAILING WINDS

THE CAUSEWAY

SITE ANALYSIS PLAN

CLIENT'S SIGNATURE:

DATE:

ClarendonHomes

BL No. 2298C
ABN 18 003 892 706

Clarendon Homes (NSW) P/L
21 Solent Circuit, Baulkham Hills NSW 2153
T: (02) 8851 5300

© ALL RIGHTS RESERVED
This plan is the property of
CLARENDON HOMES (NSW) P/L
Any copying or altering
of the drawing shall not be
undertaken without written
permission from
CLARENDON HOMES (NSW) P/L
ALL DIMENSIONS TO STRUCTURAL
ELEMENTS. DIMENSIONS TO BE READ
IN PREFERENCE TO SCALING.

PRODUCT:
BOSTON 42
Malibu
R/H Garage
Sapphire Specification

CLIENT:
Ms. TAN
SITE ADDRESS:
Lot 36 No.13
The Causeway
STRATHFIELD SOUTH 2136

DA DRAWINGS

DRAWN: PG.	DATE: 08.12.20	Rev:
RATIO @ A3: 1:200	CHECKED: J.S	H
SHEET: 2.2	JOB No: 29914372	NSW

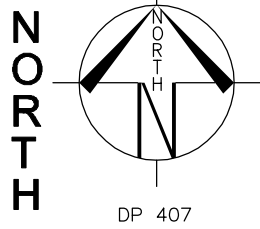

LOT 36
D.P: 407 SEC: 1
L.G.A: STRATHFIELD

SITING HAS BEEN COMPLETED
IN ACCORDANCE WITH
STRATHFIELD DCP 2005

SEC 1
 LOT 8

SEC 1
 LOT 7

SEC 1
 LOT 6

APPROX. LOCATION
 OF SEWER

SEE

SEWER

DIAGRAM

LOT 35
 SEC 1

LOT 36
580.6m²
SEC 1

PROPOSED
RESIDENCE
FFL R.L. 18.000
FGL R.L. 17.615

GARAGE
STEPDOWN
343mm
FFL R.L. 17.657
FGL R.L. 17.272

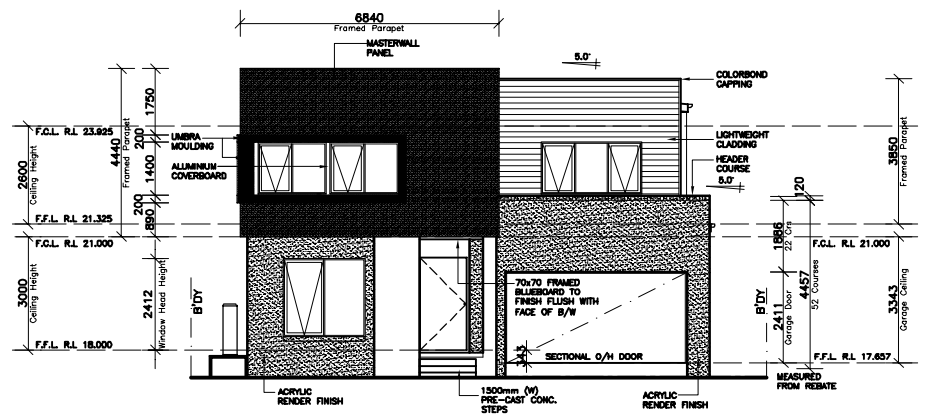

ELEVATION 1
-SOUTH-

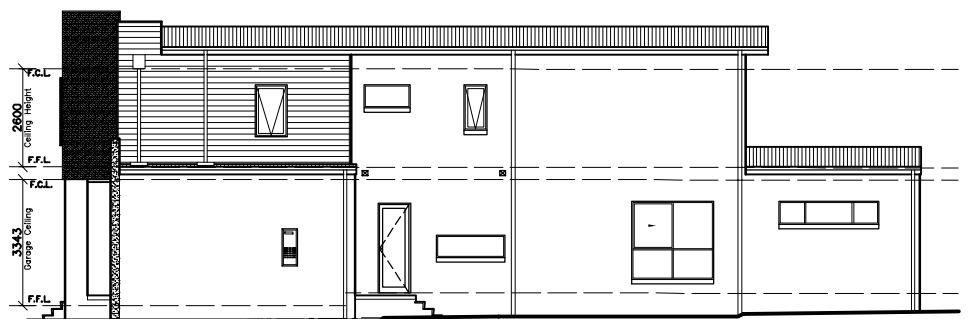

ELEVATION 2
-EAST-



ELEVATION 3
-NORTH-

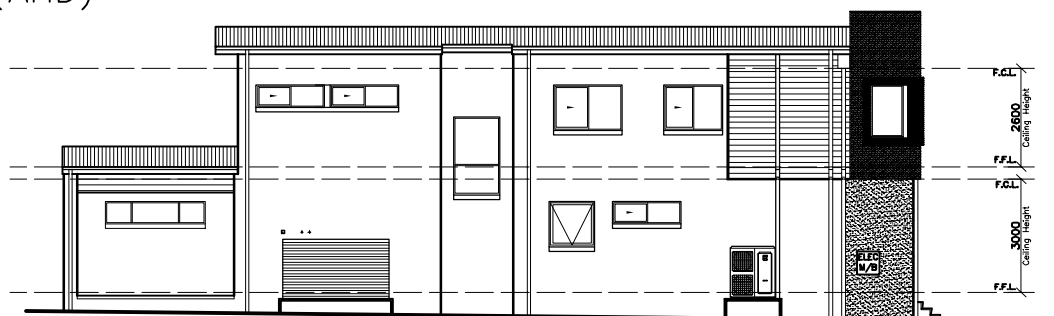

ELEVATION 4
-WEST-

THE CAUSEWAY

NEIGHBOUR NOTIFICATION PLAN

CLIENT'S SIGNATURE:

DATE:

ClarendonHomes

BL No. 2298C
 ABN 18 003 892 706
 Clarendon Homes (NSW) P/L
 21 Solent Circuit, Baulkham Hills NSW 2153
 T: (02) 8851 5300

© ALL RIGHTS RESERVED
 This plan is the property of
 CLARENDON HOMES (NSW) P/L
 Any copying or altering
 of the drawing shall not be
 undertaken without written
 permission from
 CLARENDON HOMES (NSW) P/L
 # ALL DIMENSIONS TO STRUCTURAL
 ELEMENTS. DIMENSIONS TO BE READ
 IN PREFERENCE TO SCALING.

PRODUCT:
BOSTON 42
 Malibu
 R/H Garage
 Sapphire Specification

CLIENT:
 Ms. TAN
 SITE ADDRESS:
 Lot 36 No.13
 The Causeway
 STRATHFIELD SOUTH 2136

DA DRAWINGS

DRAWN: PG.	DATE: 08.12.20	Rev: H
RATIO @ A3: 1:200	CHECKED: J.S	
SHEET: 2.3	JOB No: 29914372	NSW

North

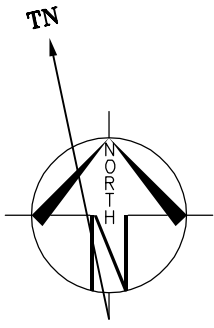

DP 407

LOT 36
D.P: 407 SEC: 1
L.G.A: STRATHFIELD

SITING HAS BEEN COMPLETED
IN ACCORDANCE WITH
STRATHFIELD DCP 2005

SEC 1
LOT 8

SEC 1
LOT 7

SEC 1
LOT 6

APPROX. LOCATION
OF SEWER

SEE

SEWER

DIAGRAM

MET 270'00'00" PAN. FCE

15.24

78.6

60.29

21.30

18.08

LOT 35
SEC 1

LOT 37
SEC 1

SHED

TWO STOREY
RENDERED, CLAD
TILE ROOF
No.11

TWO STOREY
BRICK, REND.
TILE ROOF
No.15

LOT 36
580.6m²
SEC 1

Shadow outline for JUN21-3.00pm

Shadow outline for JUN21-12.00pm

APPROX. LOCATION
OF SEWER

THE CAUSEWAY

Shadow outline for JUN21-9.00am

SHADOW DIAGRAM @ 21st JUNE

CLIENT'S SIGNATURE:

DATE:

ClarendonHomes

BL No. 2298C
ABN 18 003 892 706

Clarendon Homes (NSW) P/L
21 Solent Circuit, Baulkham Hills NSW 2153
T: (02) 8851 5300

© ALL RIGHTS RESERVED
This plan is the property of
CLARENDON HOMES (NSW) P/L
Any copying or altering
of the drawing shall not be
undertaken without written
permission from
CLARENDON HOMES (NSW) P/L
ALL DIMENSIONS TO STRUCTURAL
ELEMENTS. DIMENSIONS TO BE READ
IN PREFERENCE TO SCALING.

PRODUCT:
BOSTON 42
Malibu
R/H Garage
Sapphire Specification

CLIENT:
Ms. TAN
SITE ADDRESS:
Lot 36 No.13
The Causeway
STRATHFIELD SOUTH 2136

DA DRAWINGS

DRAWN: PG.	DATE: 08.12.20	Rev:
RATIO @ A3: 1:200	CHECKED: J.S	H
SHEET: 2.4	JOB No: 29914372	NSW